

MACC250007, Repair Hoban Hall
Drawings and Specifications
Dated: 25 March 2025

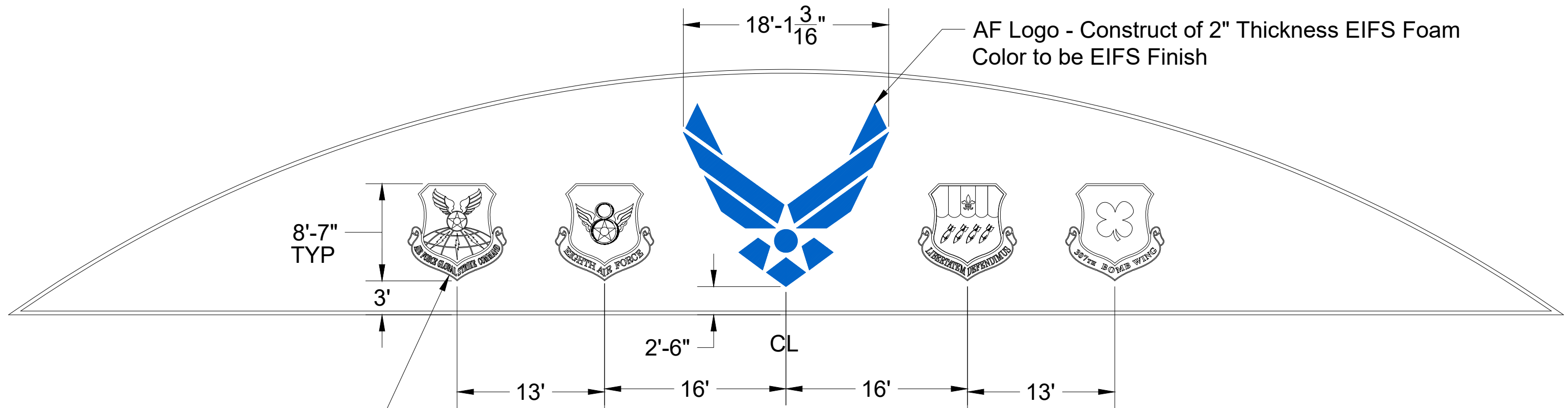

Unit Crests to be constructed of 6mm Aluminum Composite Panels, with .21 thickness aluminum sheets.
All Graphics are to be direct printed with UV stable ink.
Signs are to mechanically mounted with hidden fasteners.
Official graphics and colors will be provided.



SECTION OF WALL DAMAGED FROM STORM



SECTION OF WALL FROM STORM



EXTERIOR MATERIAL , PAPER, 2X2, METAL WIRE GRID, 1" OF GYPSUM MATERIAL, AND SEVERAL LAYERS OF PAINT.

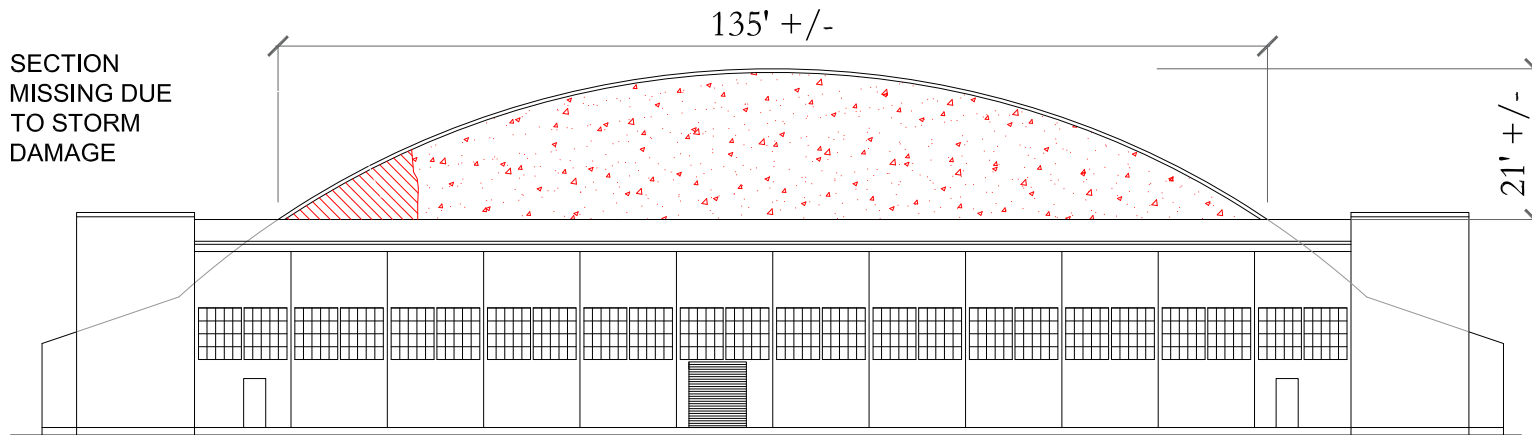

SECTION MISSING DUE TO STORM DAMAGE

APPROXIMATELY 2,000 SQ.FT. OF 1" THICK EXTERIOR MATERIAL TO BE REMOVED.
REPLACE WITH APPROXIMATELY 2,000 SQ.FT. SEE DETAIL
135 L.F. FLASHING ON LOWER ROOF TRANSITION AND 142 L.F. FLASHING ON TOP ARCH



EXTERIOR MATERIAL



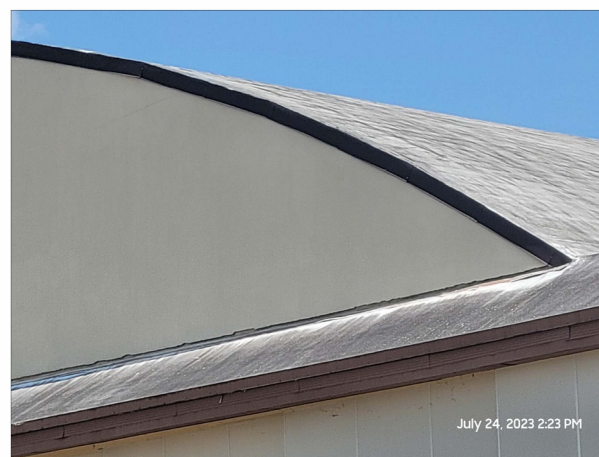

FRONT ENTRANCE, LETTER AND SHIELDS TO BE REMOVED AND NEW ONES INSTALLED.

FLASHING & TRANSITION

OVERALL

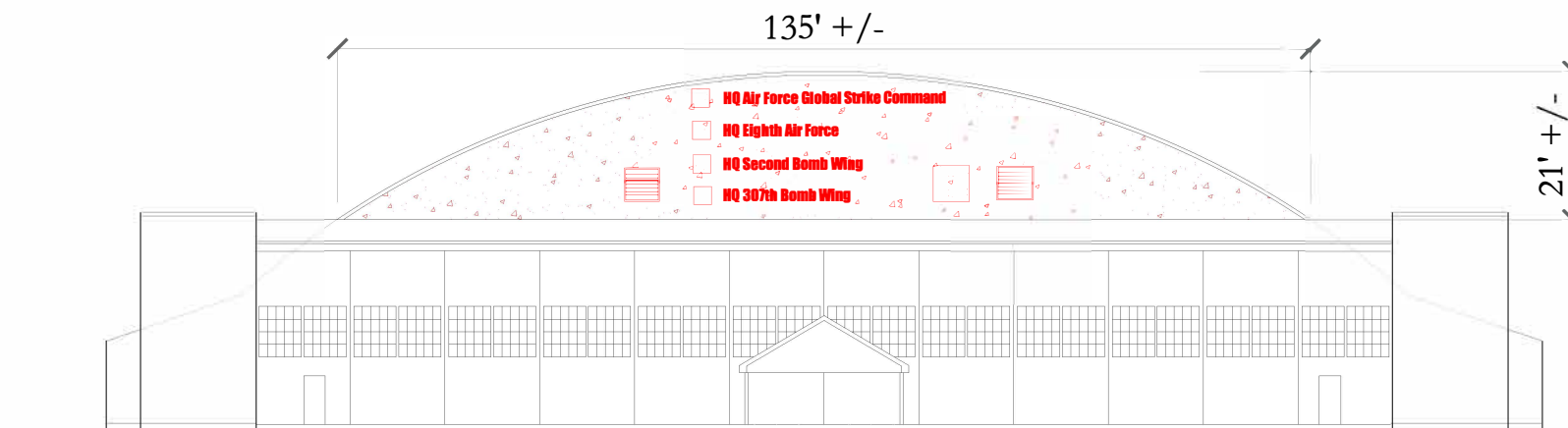

APPROXIMATELY 2,000 SQ.FT. OF 1" THICK EXTERIOR MATERIAL TO BE REMOVED.
REPLACE WITH APPROXIMATELY 2,000 SQ.FT. SEE DETAIL
135 L.F. FLASHING ON LOWER ROOF TRANSITION AND 142 L.F. FLASHING ON TOP ARCH
REMOVE SIGNS, SYMBOLS, LETTERS.
INFILL GRILLS (APPROXIMATELY 5' X 5') WITH NEW WALL MATERIAL



PROJECT : REPAIR HOBAN HALL
BUILDING: B6448
DATE : 07/27/2023

138T Shingle Recover System

McElroy Metal's 138T Shingle Recover System provides a long-term and economical solution for building owners.

138T's symmetrical standing seam panel offers many advantages including: ease of installation, individual panel replaceability and improved weathertightness. This innovative system installs directly over existing shingles without tear off or underlayment. Patented clips create an energy saving airspace between the two roofs.

138T Shingle Recover System offers:

- + **Ease of installation**
- + **No tear off / disposal of existing roof**
- + **No underlayment required**
- + **Decades long service life**
- + **Reduced utility expense**



Quicker Payback



138T Shingle Recover System

No Tear-Off Required

As long as the deck is serviceable, there is no need for the added expense and hassle of removing and disposing of the existing shingles (please check with your local code authority to determine if one or two layers of shingles are allowable for recover). Because the **138T** clip creates airspace between the existing and new roof, the added expense of applying an underlayment is eliminated.

138T Recover Clip

Clip alignment is the key to a proper installation of a standing seam recover over shingles. The patent pending **138T** clip is long enough to sit on two shingles simultaneously. This feature aligns the clip into the plane of the roof. The clip also holds the panel up 3/4" above the existing roof. Even with this 3/4" gap, the panels are walkable without causing damage. The system also features vented eave and ridge components, which when combined with the **138T** clip, enables uninterrupted airflow between the existing and new roof.

Above Sheathing Ventilation (ASV)

Utilizing an air space to help reduce heat transfer is not new. Oak Ridge National Laboratories has tested and documented that a free flowing air space between a metal roof and shingles can reduce heat transfer by 25%. Up until now, the common method to provide ASV was to install a series of vertical and horizontal framing members which greatly increased material and labor expense. The **138T** Shingle Recover clip eliminates all framing and allows unencumbered airflow in all directions. Although this recover system was designed for retrofit applications, it is equally suitable for new construction.



The patented 138T Shingle Recover Clip is installed with two fasteners into the existing substrate and allows for a 3/4" airspace between existing and new roofs.



Image shows clip seated on two shingles with fasteners through lower ends of the shingles.



Corrugated sheeting installed at the ridge allows for continuous air flow between the existing and new roof while providing support for the panel and closure.

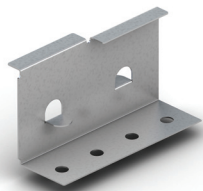

4" ASV clip

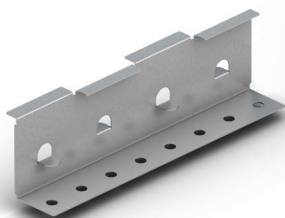

8" shingle recover clip with ASV



138T with "Plank and Pencil Rib"

* 4" ASV clip for new construction or remove and replace



Corporate Office
1500 Hamilton Rd.
Bossier City, LA 71111
www.mcelroymetal.com
info@mcelroymetal.com

HI-SIDE TIE-IN DETAIL (FIXED)

SLOPES LESS THAN 3:12 WILL REQUIRE THE PAN OF THE PANEL TO BE FOLDED UP.

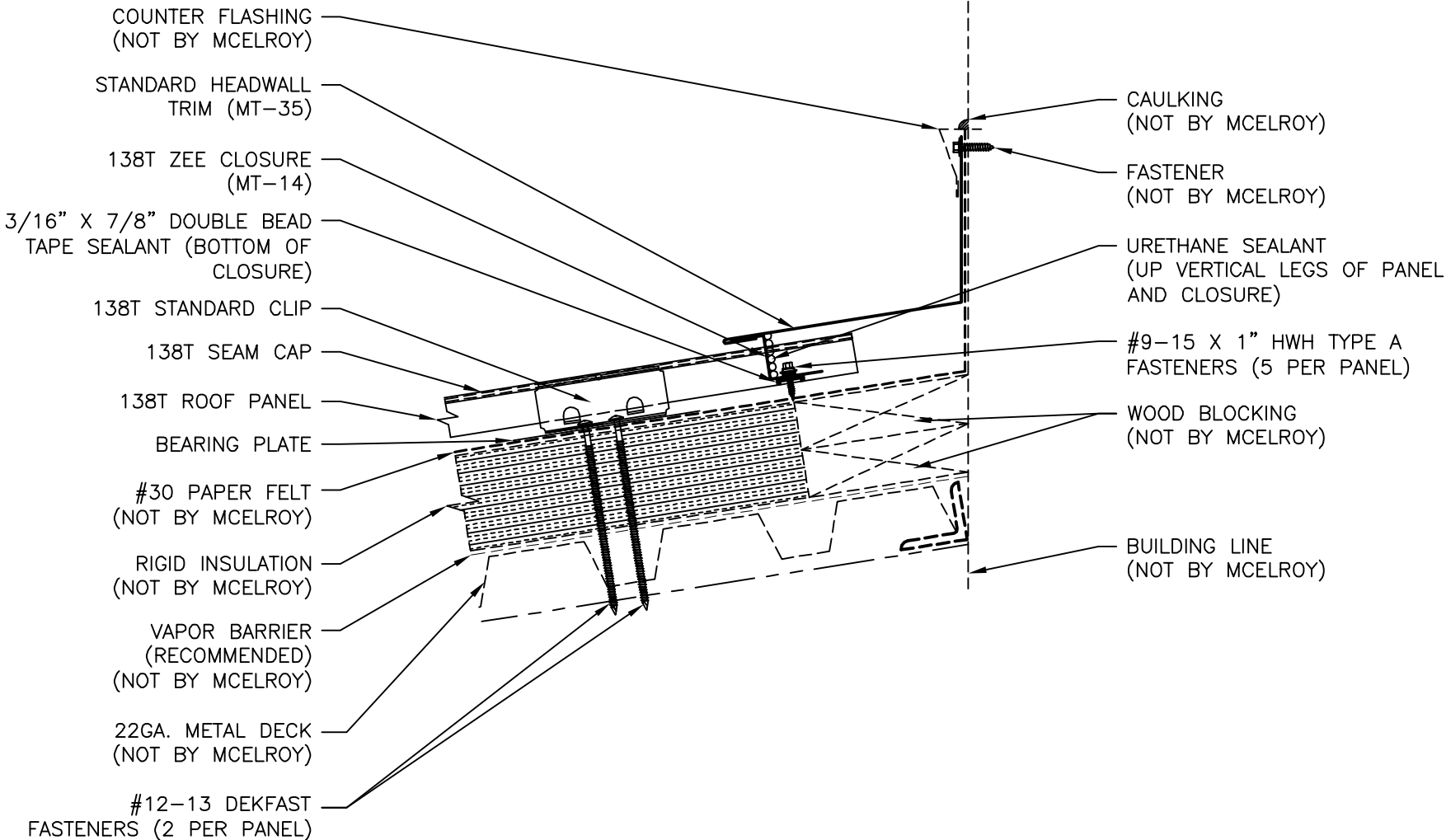

138T ASV

EAVE

** CLEARANCE REQUIRED FOR THERMAL MOVEMENT

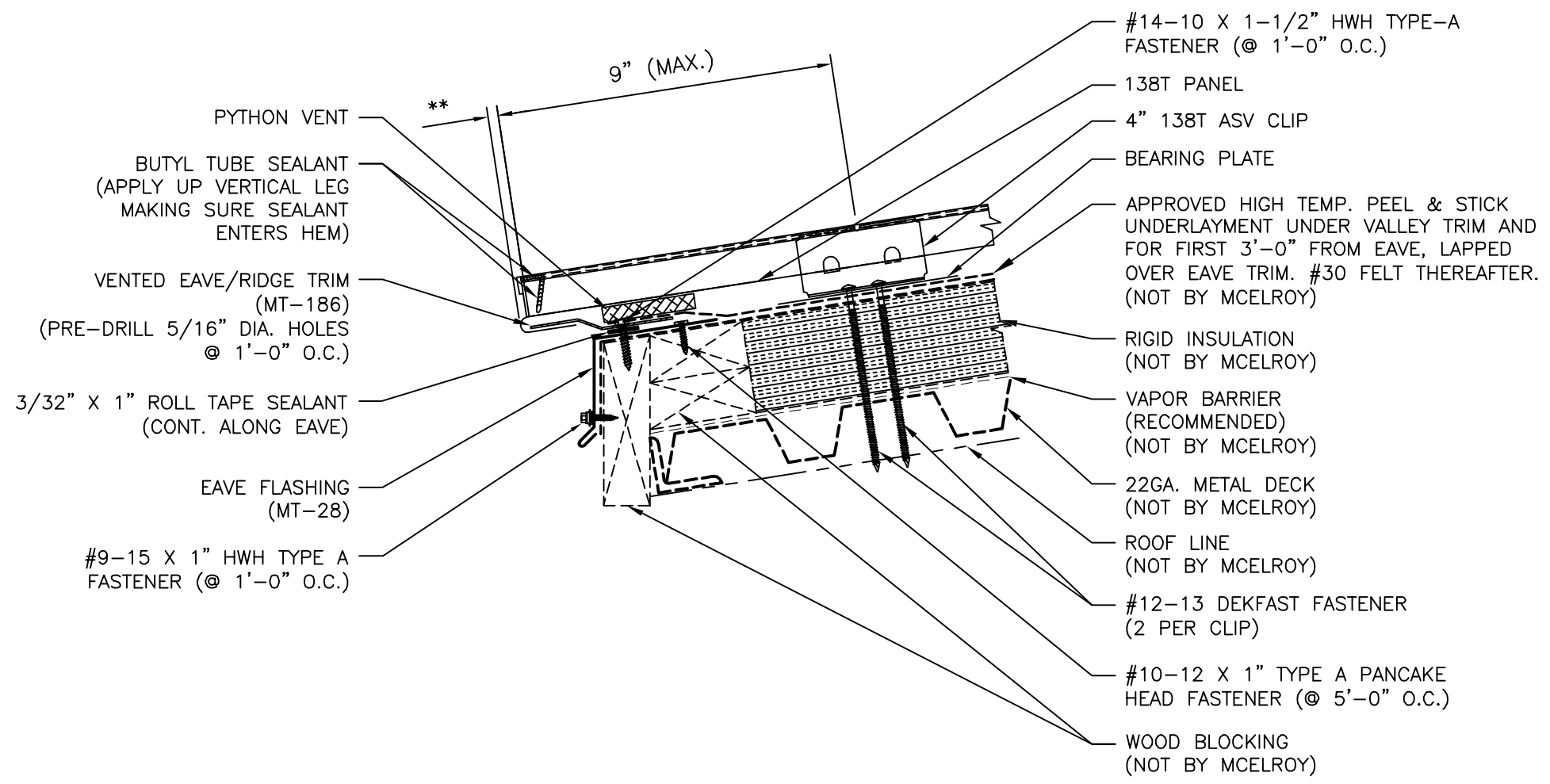

Description

Cement Board MD Finish System consists of an acrylic-modified base coat with reinforcing mesh embedded and finish applied over an approved exterior cement board. The exterior cement board meeting ASTM C 1325 (by others) and fasteners (by others) are applied over Dryvit MD Spacers™ (drainage medium), Dryvit Backstop NT™ or other code approved water-resistant barrier and approved exterior sheathing.

Uses

Cement Board MD Finish System is applied over approved sheathing substrates in residential and low-rise commercial applications when exterior insulation is not required.

Coverage

All coverages are approximate and may vary slightly, depending on substrate, details and individual application technique.

Dryvit Components

Backstop NT - Texture: 230-300 ft² (23-28 m²) per 5 gal (19 L) pail, including joint treatment, when applied by roller in accordance with Dryvit recommendations.

Backstop NT - Smooth: Approximately 500 ft² (46 m²) per 5 gal (19 L) pail, when applied by roller in accordance with Dryvit recommendations.

Genesis®: Approximately 250 ft² (23 m²) of surface area per 60 lb (27 kg) pail. Coverage rate includes embedding strips of Detail Mesh® at all exterior cement board sheathing joints and a continuous layer of reinforcing mesh over the entire exterior cement board face.

Genesis® DM: Approximately 105 ft² (10 m²) of surface area per 50 lb (23 kg) bag. Coverage rate includes embedding strips of Detail Mesh at all exterior cement board sheathing joints and a continuous layer of reinforcing mesh over the entire exterior cement board face.

Genesis® DMS: Approximately 118 ft² (11 m²) of surface area per 50 lb (23 kg) bag. Coverage rate includes embedding strips of Detail Mesh at all exterior cement board sheathing joints and a continuous layer of reinforcing mesh over the entire exterior cement board face.

Reinforcing Mesh: Standard 4 ft x 150 ft (1.2 m x 46 m) provides 600 ft² (56 m²) of coverage.

Finishes: Refer to the individual product data sheets for the specified finish.

Application Procedure

Job Conditions - Air and surface temperature for application of Cement Board MD Finish System materials must be 40°F (4°C) or higher and must remain so for a minimum of 24 hours.

Temporary Protection - Must be provided at all times to protect against damaging effects of precipitation, dirt and job-site contamination.

Substrates/Preparation - Surfaces must be above 40°F (4°C) or higher and must be clean, dry, structurally sound and free of efflorescence, grease, oil and paint.

Mixing - Dryvit materials must be mixed in accordance with current Dryvit literature.

Application - Cement Board MD Finish System materials must be applied in accordance with current Dryvit Cement Board MD Finish System Specifications,

DS191. Dryvit finishes must be applied in accordance with published Dryvit instructions for the specific finish being used. Refer to the published product sheet for the appropriate finish.

Clean-Up - Clean tools with water while product is still wet.

Storage

Store bags and pails on pallets, wrapped or covered, protected from the weather and out of direct sunlight. Wet goods must be stored at a minimum of 40°F (4°C) and a maximum of 100°F (38°C) in tightly sealed containers protected from weather and out of direct sunlight.

Cautions and Limitations*

- Avoid applying wet goods in direct sunlight. Always work on the shady side of the wall or protect the area with appropriate shading material.
- Use is limited to applications on projects not exceeding 5 stories.
- Minor cracking is possible in the finished exterior surface.
- Non-insulated claddings may exhibit shadowing (ghosting) of fasteners and or framing members due to varying exterior surface temperatures.
- Critical light will tend to exaggerate construction irregularities when coatings are applied directly to sheathing in framed construction.
- Base coat material shall not be used to level wall surface imperfections.

- Consult exterior cement board manufacturer requirements for stud spacing, fastening requirements and other design and installation considerations.

*Exterior cement board direct applied systems have limited design freedom and performance compared to exterior insulation and finish systems. Refer to Dryvit's Outsulation® family of insulated wall cladding for increased design and performance.

Technical and Field Services

Available on request.



DS191

CEMENT BOARD MD FINISH SYSTEM™

**An Exterior Finish System Applied Over Exterior Cement Board
With A Water-Resistive Barrier And Moisture Drainage**

Cement Board MD Finish System Specifications

DRYVIT SYSTEMS, INC.
MANUFACTURER'S SPECIFICATION
CSI MASTERFORMAT SECTION 07 24 23
CEMENT BOARD MD FINISH SYSTEM

PART I - GENERAL

1.01 SUMMARY:

This document is intended to be used in preparing specifications for projects utilizing Cement Board MD Finish System by Dryvit. For complete product description and usage refer to:

- A. Dryvit Cement Board MD Data Sheet, [DS480](#)
- B. Dryvit Cement Board MD Installation Details, [DS190](#)

1.02 RELATED SECTIONS

- A. Project Meetings – Section 01 31 19
- B. Cold-Formed Metal Framing – Section 05 40 00
- C. Wood Framing – Section 06 11 00
- D. Flashing and Sheet Metal – Section 07 60 00
- E. Joint Protection – Section 07 90 00

1.03 REFERENCES

- A. AC59 Acceptance Criteria for Direct-Applied Exterior Finish Systems.
- B. AC148 Acceptance Criteria for Flashing Materials.
- C. ASTM B 117 (Federal Test Standard 141A Method 6061) Test Method of Salt Spray (Fog) Testing.
- D. ASTM C 79 Specification for Gypsum Sheathing Board.
- E. ASTM C 150 Specification for Portland Cement.
- F. ASTM C 297 Test Method for Tensile Strength of Flat Sandwich Constructions in Flatwise Plane.
- G. ASTM C 1177 Specification for Glass Mat Gypsum Substrate for Use as Sheathing.
- H. ASTM C 1325 Standard Specification for non-asbestos fiber-mat reinforced cementitious backer units.
- I. ASTM C 1516 Standard Practice for Application of Direct-Applied Exterior Finish Systems.
- J. ASTM D 968 (Federal Test Standard 141A Method 6191) Test Method for Abrasion Resistance of Organic Coatings by Falling Abrasive.
- K. ASTM D 2898 Standard Test Method for Accelerated Weathering of Fire-Retardant-Treated Wood for Fire Testing
- L. ASTM D 3273 Test Method for Resistance to Growth of Mold on Surfaces.
- M. ASTM E 84 Test Method for Surface Burning Characteristics of Building Materials.
- N. ASTM E 96 Test Methods for Water Vapor Transmission of Materials.
- O. ASTM G 23 (Federal Test Standard 141A Method 6151) Recommended Practice for Operating Exposure Apparatus (Carbon-Arc Type) With and Without Water, for Exposure of Nonmetallic Materials.

1.04 SUBMITTALS

- A. Submittal requirements by the contractor are to be indicated in the construction documents as required, including:
 - 1. Product literature, samples or mock-up.
 - 2. Finish sample indicating color and texture for approval by architect/owner.

1.05 DESCRIPTION

- A. Cement Board MD Finish System consisting of Dryvit base coat with reinforcing mesh, and finish applied over an exterior cement board that is installed over a code approved water-resistive barrier and approved drainage medium. The substrate, cement board, and water-resistive barrier (unless the water-resistive barrier is manufactured by Dryvit) are not part of the system.
 - 1. Design Requirements:
 - a. A sheathing board substrate installed over structural framing prior to installation of a code approved water-resistive barrier shall be one of the following:
 - 1) Exterior sheathing having a water-resistant core with fiberglass mat facers meeting ASTM C 1177.
 - 2) Exterior fiber reinforced cement meeting ASTM C 1325 or calcium silicate boards.
 - 3) APA Exterior or Exposure 1 Rated Plywood, Grade C-D or better, nominal 1/2 in (12.7 mm), minimum, installed with the C face out.
 - 4) APA Exterior or Exposure 1 Fire Retardant Treated (FRT) Plywood, Grade C-D or better, nominal 1/2 in (12.7 mm), minimum, installed with the C face out.
 - 5) APA Exposure 1 Rated Oriented Strand Board (OSB) nominal 1/2 in (12.7 mm), minimum. **NOTE: Applications over OSB sheathing requires a minimum of 2 coats of Backstop NT – Smooth or Spray. Backstop NT – Texture is not recommended for the field of wall application over OSB.**
 - b. The outer layer sheathing shall be exterior cement board meeting ASTM C 1325, minimum 1/2 in (12.7 mm).
 - c. The roofing materials shall be loaded onto the roof and interior wallboard stocked in the building prior to the installation of the Cement Board MD Finish System.

- d. Deflection of substrate systems shall not exceed L/360.
 - e. The slope of inclined surfaces shall not be less than 6:12 (27°) and the length shall not exceed 12 in (305 mm).
 - f. Expansion joints:
 - 1) Design and location of expansion/control joints in the substrate shall be determined by the project design professional and indicated on the contract documents. As a minimum, joints in Cement Board MD Finish System are required at the following locations:
 - a) Where expansion joints occur in the substrate system
 - b) Where building expansion joints occur
 - c) At floor lines in wood frame construction
 - d) Where Cement Board MD Finish System abuts dissimilar materials
 - e) Where the substrate changes
 - f) Where significant structural movement occurs such as changes in roofline, building shape or structural system
 - g. Control joints:
 - 1) Design and location of control joints shall be determined by the design professional. As a minimum, control joints shall be located at the following locations:
 - a) Corners of openings.
 - b) Such that wall lengths do not exceed 20 ft (6 m).
 - c) Length to width ratios of wall areas shall not exceed 2.5:1.
 - h. Sealants
 - 1) Use and location of sealants is the responsibility of the project designer and shall be indicated on the contract documents.
 - 2) Refer to Section 07 90 00.
 - 3) Refer to Dryvit publication [DS153](#) for a list of sealants that have been tested for compatibility with Dryvit products.
 - i. Vapor Retarders
 - 1) Use and location of vapor retarders within a wall assembly is the responsibility of the project designer and shall comply with local building code requirements. Type and location shall be noted on the contract documents. Vapor retarders may be inappropriate in certain climatic zones and can result in condensation within the wall assembly when incorrectly used. Refer to Dryvit publication [DS159](#) for additional information.
 - j. Flashing
 - 1) Flashing: shall be provided at all roof-wall intersections, windows, doors, chimneys, decks, balconies, and other areas as necessary to prevent water penetration behind Cement Board MD Finish System.
 - k. Site Coated EPS Shapes and Starter Boards: Shall be coated on site utilizing the same materials (EPS, base material mixture, reinforcing mesh, and finish) as specified for the project.
 - l. Machine Coated EPS Shapes and Starter Boards: Shall be supplied by a manufacturer that subscribes to the Dryvit third party certification and quality assurance program.
2. Performance Requirements: As a minimum, the Dryvit Cement Board MD Finish System products shall be tested as follows:
- a. ASTM B 117: Salt Spray Resistance – 300 hrs, no deleterious effects.
 - b. ASTM C 297 Bond Strength – Failure in the substrate.
 - c. ASTM D 968: Abrasion Resistance – 132 gal (500 L), no deleterious effects.
 - d. ASTM D 3273 Mildew/Fungus Resistance – Passed.
 - e. ASTM E 84 Flame Spread – Flame Spread Index less than 25, Smoke Developed less than 250.
 - f. ASTM E 96 Water Vapor Transmission – Vapor Permeable.
 - g. ASTM G 23 Accelerated Weathering – 2000 hrs, Passed.

1.06 QUALITY ASSURANCE

A. Qualifications:

- 1. Manufacturer: Shall be Dryvit Systems, Inc. or approved suppliers. All materials shall be obtained from Dryvit Systems, Inc. or its authorized distributors.
- 2. Material shall be manufactured at a facility covered by a current ISO 9001:2015 and ISO 14001:2015 certification. Certification of the facility shall be by a registrar accredited by the American National Standards Institute-Registrar Accreditation Board (ANSI-RAB).
- 3. Plastering Contractor:
 - a. Shall be knowledgeable in the proper installation of Cement Board MD Finish System components.
 - b. Shall have qualified and properly trained people to perform work.
 - c. Shall be licensed, bonded and insured.
 - d. Shall have experience in application of direct-applied exterior finish systems on projects of comparable scope.

4. Third Party Inspection

- a. Owner's independent third-party inspection is recommended to verify installation according to code and contract documents. It is recommended that as a minimum, inspection items include installation of the water-resistive barrier, flashings and accessories, Cement Board MD Finish System materials and sealants. The intent is to verify that the installation has been performed in accordance with code requirements, contract requirements and this specification.

5. Machine Coated EPS Shapes and Starter Boards: Shall be supplied by a manufacturer that subscribes to the Dryvit third party certification and quality assurance program.

B. Mock-Up

1. The contractor shall, before the project commences, provide the owner/architect with a mock-up for approval.
2. The mock-up shall be of suitable size as required to accurately represent each color and texture to be utilized on the project.
3. The mock-up shall be prepared with the same products, tools, equipment and techniques required for the actual applications. The finish used shall be from the same batch as that being used for the project.
4. The approved mock-up shall be available and maintained at the job site.

1.07 DELIVERY, STORAGE AND HANDLING

A. All Dryvit materials shall be delivered to the job site in the original, unopened packages with labels intact.

B. Upon arrival, materials shall be inspected for physical damage, freezing or overheating. Questionable materials shall not be used.

1. Materials shall be stored at the job site, and at all times, in a cool, dry location, out of direct sunlight, protected from weather and other sources of damage. Minimum storage temperature shall be as follows:

- a. DPR, PMR™, HDP™, Weatherlastic® and E™ Finishes, Color Prime™, Primus®, Genesis® and NCB™, 40 °F (4 °C).
- b. For other products, refer to specific product data sheets.

2. Maximum storage temperature shall not exceed 100 °F (38 °C). **NOTE: Minimize exposure of materials to temperatures over 90 °F (32 °C). Finishes exposed to temperatures over 110 °F (43 °C) for even short periods may exhibit skinning, increased viscosity and should be inspected prior to use.**

C. Protect all products from inclement weather and direct sunlight.

1.08 PROJECT CONDITIONS

A. Environmental Requirements

1. Application of wet materials shall not take place during inclement weather unless appropriate protection is provided. Protect materials from inclement weather until they are completely dry.
2. At the time of Dryvit product application, the air and wall surface temperatures shall be from 40 °F (4 °C) minimum to 100 °F (38 °C) maximum for the following products:
 - a. DPR, PMR, HDP, Weatherlastic and E Finishes, Color Prime, Primus, Genesis and NCB.
 - b. For other products, refer to specific product data sheets.
3. These temperatures shall be maintained with adequate air ventilation and circulation for a minimum of 24 hours (48 hours for Weatherlastic Finishes, Ameristone, and TerraNeo) thereafter, or until the products are completely dry. Refer to published product data sheets for more specific information.

1.09 SEQUENCING AND SCHEDULING

A. Installation of Cement Board MD Finish System shall be coordinated with other construction trades.

1.10 WARRANTY

A. Dryvit Systems, Inc. shall provide a written limited materials warranty against defective material upon written request. Dryvit shall make no other warranties, expressed or implied. Dryvit does not warrant workmanship. Full details are available from Dryvit Systems, Inc.

B. The applicator shall warrant workmanship separately. Dryvit shall not be responsible for workmanship associated with installation of the Cement Board MD Finish System.

1.11 DESIGN RESPONSIBILITY

A. It is the responsibility of both the specifier and the purchaser to determine if a product is suitable for their intended use. The designer selected by the purchaser shall be responsible for all decisions pertaining to design, detail, structural capability, attachment details, shop drawings and the like. Dryvit has prepared guidelines in the form of specifications, application details, and product data sheets to facilitate the design process only. Dryvit is not liable for any errors or omissions in design, detail, structural capability, attachment details, shop drawings, or the like, whether based upon the information prepared by Dryvit or otherwise, or for any changes which purchasers, specifiers, designers, or their appointed representatives may make to Dryvit's published comments.

1.12 MAINTENANCE

- A. All Dryvit products are designed to require minimal maintenance. However, as with all building products, depending on location, some cleaning and minimal maintenance may be required. See Dryvit publication [DS152](#) on Cleaning and Recoating.
- B. Sealants and flashings shall be inspected by the owner or their agent on a regular basis and repairs made as necessary.

PART II-PRODUCTS

2.01 MANUFACTURER:

- A. All components of the Cement Board MD Finish System shall be obtained from Dryvit or its authorized distributors.

2.02 MATERIALS

- A. Water-Resistive Barrier (not a component of the Dryvit finish system except for Backstop® NT™).
 - 1. Dryvit Backstop NT: A vapor permeable, flexible, polymer-based noncementitious water-resistive and air barrier coating available in Texture, Smooth, and Spray. See [DS180](#) and [DS181](#).
 - 2. Dryvit Backstop NT-VB: A Class 1 vapor retarder, available in trowel and spray versions. When specified, consider having a WVT analysis performed. See [DS830](#) and [DS831](#).
 - 3. Dryvit Grid Tape™: A 4 in (102 mm) wide, open weave fiberglass mesh tape used to reinforce sheathing joints and exposed edges of sheathing.
 - 4. Other code approved water-resistive barrier (when selected by others) is not a component of the Dryvit finish system.
- B. Dryvit MD Spacer™: A polyethylene spacer, which separates the exterior cement board from the sheathing substrate. If other spacers are used, they are not part of the Dryvit finish system.
- C. Exterior Cement Board (by others) and cement board fasteners (by others) are not components of the Dryvit finish system.
- D. Dryvit Base Coat
 - 1. Cementitious: A liquid polymer based material, which is field mixed in a 1:1 ratio by weight with Portland Cement.
 - a. Shall be Genesis®.
 - 2. Ready mixed: A dry blend cementitious, polymer-based product, field mixed with water.
 - a. Shall be Genesis® DM.
 - 3. Sprayable: A dry blend cementitious, polymer-modified product, field mixed with water and specifically formulated for spray applications to provide longer pot life, less false set, extended open time and stronger wet grip.
 - a. Shall be Genesis® DMS.
- E. Machine Coated EPS Shapes and Starter Boards: Shall be supplied by a manufacturer that subscribes to the Dryvit third party certification and quality assurance program.
- F. Reinforcing Mesh(es): Shall be a balanced open weave, glass fiber fabric treated for compatibility with other system materials.
 - 1. Dryvit Detail Mesh®: 4.3 oz/yd² (146 g/m²), 9 1/2 in (241 mm) wide. Required at all exterior cement board joints and inside and outside corners.
 - 2. Dryvit Standard Mesh: 4.3 oz/yd² (146 g/m²). Shall be installed over the entire exterior cement board face.
- G. Dryvit Finish: Shall be the type, color and texture as selected by the owner/architect and shall be one or more of the following:
 - 1. Standard DPR (Dirt Pickup Resistance): Water based, acrylic coatings with integral color and texture and formulated with DPR chemistry:
 - a. Quarzputz® DPR: Open-texture pattern.
 - b. Sandblast® DPR: Medium texture.
 - c. Freestyle® DPR: Fine texture.
 - d. Sandpebble® DPR: Pebble texture.
 - e. Sandpebble® DPR Fine: Fine pebble texture.
 - 2. Hydrophobic (HDP™) Finishes: 100% acrylic coating with integral color and texture and formulated with hydrophobic properties:
 - a. Quarzputz® HDP
 - b. Sandblast® HDP
 - c. Sandpebble® HDP
 - d. Sandpebble® Fine HDP

3. **E** Finishes™: Water-based, lightweight acrylic coatings™ with integral color and texture and formulated with DPR chemistry:
 - a. Quarzputz® **E**
 - b. Sandpebble® **E**
 - c. Sandpebble® Fine **E**
4. Specialty Finishes and Veneers:
 - a. Ameristone™: Multi colored quartz aggregate.
 - b. Stone Mist®: Ceramically colored quartz aggregate.
 - c. Custom Brick™: Acrylic polymer finish used in conjunction with a proprietary template system to create the look of stone, brick, slate or tile.
 - d. TerraNeo®: 100% acrylic-based finish with large mica chips and multi-colored quartz aggregates.
 - e. NewBrick®: A lightweight insulated brick veneer for use on exterior walls.
5. Elastomeric DPR (Dirt Pickup Resistance) Finishes: Water-based, elastomeric acrylic finishes with integral color and texture and formulated with DPR chemistry:
 - a. Weatherlastic® Quarzputz
 - b. Weatherlastic® Sandpebble
 - c. Weatherlastic® Sandpebble Fine
 - d. Weatherlastic® Adobe
6. Medallion Series PMR™ (Proven Mildew Resistance) Finishes: Water based, acrylic finishes with integral color and texture:
 - a. Quarzputz® PMR
 - b. Sandblast® PMR
 - c. Freestyle® PMR
 - d. Sandpebble® PMR
 - e. Sandpebble® Fine PMR
7. Coatings, Primers and Sealers:
 - a. Demandit® Smooth
 - b. Demandit® Sanded
 - c. Demandit® Advantage™
 - d. HDP Water-Repellent Coating
 - e. Weatherlastic® Smooth
 - f. Tuscan Glaze™
 - g. Color Prime™
 - h. Prymit®
 - i. SealClear™
- H. Expanded polystyrene (if applicable): Shall be 1 pcf nominal density meeting [DS131](#). EPS must meet the specification of Dryvit Systems, Inc. and be produced by a manufacturer licensed by Dryvit.
- I. Accessories (by others) are not components of the Dryvit finish system.
 1. Type, style and manufacturer shall be indicated on construction documents.
 2. In corrosive environments, accessories manufactured of PVC or zinc are recommended.
 3. Steel accessories shall meet ASTM C 841.
 4. PVC accessories shall meet ASTM D 1784 and C 1063.

PART III-EXECUTION

3.01 EXAMINATION

- A. Prior to installation of the Cement Board MD Finish System, it is the contractor's responsibility to ensure that:
 1. The sheathing substrate is of a type listed in Section 1.05 A.2.a.
 2. The sheathing substrate and the exterior cement board surface are free of dust, loose particles, oil and other conditions that would affect the adhesion or installation of Cement Board MD Finish System materials.
 3. All fasteners are corrosion resistant and installed in a manner as to be flush with the surface of the cement board.
 4. All accessories including corner aids, control and expansion joints, casing beads, etc. are properly fastened and positioned according to contract drawings, manufacturer requirements and local building code requirements.
 5. The water-resistive barrier is of a proper type and, if sheet form, has been installed in a weatherboard fashion in accordance with building code and manufacturer's requirements.
 6. Doors, windows, decks, and other openings and penetrations have been properly flashed in accordance with manufacturer requirements, building code and contract documents.
 7. Metal roof flashing has been installed in accordance with Asphalt Roofing Manufacturers Association (ARMA) Standards.
 8. The cement board surface is flat within 1/4 in (6.4 mm) in 10 ft (3 m).
 9. The contractor shall notify the general contractor and/or owner and/or architect of all discrepancies. Do not proceed until unsatisfactory conditions are resolved.

3.02 PREPARATION

- A. The Cement Board MD Finish System materials shall be protected by permanent or temporary means from weather and other damage prior to, during, and following application, until dry.
- B. Protect adjoining work and property.

3.03 INSTALLATION

A. Mixing:

- 1. Backstop NT: Due to shipping and storage, there may be some settling of materials. Prior to using, mix the material to a smooth homogeneous consistency.
- 2. Dryvit base coat materials shall be mixed in accordance with current Dryvit printed Product Sheets.
 - a. Dryvit Genesis shall be mixed in a 1:1 ratio with Portland cement. The mix is allowed to set for 5 minutes and then remixed to break the set. Refer to Genesis product sheet [DS417](#) for complete instructions.
 - b. Dryvit Genesis DM shall be mixed with water to a uniform consistency, allowed to set for 10 minutes and then remixed to break the set. Refer to Genesis DM product sheet [DS452](#) for complete instructions.
 - c. Dryvit Genesis DMS shall be mixed with water to a uniform consistency, allowed to set for 5 minutes and then remixed to break the set. Refer to Genesis DMS product sheet [DS471](#) for complete instructions.
- 3. Dryvit Finishes:
 - a. Dryvit Finishes are factory blended and require no additives. Mix each pail to a uniform consistency adding a small amount of water as needed to adjust workability. Ensure that the same amount of water is added to each pail of the same color.
 - b. Refer to the product data sheet for the specific finish being used for more complete instructions.

B. Application of Backstop NT:

- 1. Prepare the substrate sheathing so as to be free of foreign materials such as oil, dust, dirt, paint, wax, water repellents, moisture, frost and any other materials that may inhibit adhesion.
- 2. Backstop NT can be applied using a roller, trowel, or spray equipment (with backrolling) over the approved substrates. Refer to Backstop NT Application Instructions, [DS181](#).

C. Installation of Dryvit MD Spacer:

- 1. Secure the Dryvit MD Spacer to the substrate using corrosion resistant staples through the water-resistive barrier and into the substrate or framing. The spacer is 1/8 in (3.2 mm) thick by 3 in (76 mm) wide and is installed in continuous vertical strips spaced a maximum of 16 in (406 mm) on center installed over each framing member. Additionally, install the spacer flush with the vertical edge of all system terminations and changes in wall direction. If other spacers are used, follow manufacturers' instructions.

D. Install the exterior cement board in accordance with manufacturer's instructions and project requirements.

- 1. Align sheathing joints with the MD Spacer and install fasteners through the MD Spacer or other spacers as needed.
- 2. Do not align joints with corners of wall penetrations.
- 3. Exterior cement board joints shall be offset from sheathing board substrate joints.

E. Foam shape application (if applicable)

- 1. Adhere EPS shape to exterior cement board prior to applying the base coat.
- 2. Install in accordance with current Dryvit printed Outsulation® System Application Instructions [DS204](#).

F. Application of Base Coat:

- 1. Apply Genesis or Genesis DM over all exterior cement board joints and inside and outside corners and embed a 9 1/2 in (241 mm) wide strip of Dryvit Detail Reinforcing Mesh into the wet base coat mixture.
- 2. Allow the base coat mixture to take up until firm to the touch.
- 3. Apply a continuous layer of Genesis, Genesis DM or Genesis DMS over the exterior cement board face and embed a layer of Dryvit Standard Reinforcing Mesh into the wet base coat mixture such that the entire surface of the board is covered. The reinforced base coat shall be applied to a uniform thickness of approximately 1/16 in (1.6 mm) and be sufficient to embed the reinforcing mesh.
- 4. All edges of reinforcing mesh shall be lapped a minimum of 2 1/2 inches (64 mm).

G. Application of Finishes:

- 1. Allow the Genesis, Genesis DM or Genesis DMS to cure a minimum of 24 hours until completely dry.
- 2. Ensure that the surface of the wall is clean, dry and free of any contaminants that may impair the adhesion of surface finish.
- 3. Dryvit finishes may be either spray or trowel applied.
- 4. Always apply the finish to a natural break to avoid visible cold joints.
- 5. Always work the shady side of the wall or provide shading to avoid application in direct sunlight.
- 6. Dryvit finishes shall be applied in accordance with published Dryvit instructions for the specific finish being used. Refer to the published product data sheet for the specified finish.

H. The installation of Pre-Coated EPS Shapes and Starter Boards shall be in accordance with Dryvit Publication [DS854](#).

3.04 FIELD QUALITY CONTROL

- A. The contractor shall be responsible for the proper application of the Cement Board MD Finish System materials.
- B. Dryvit assumes no responsibility for on-site inspections or application of its products.
- C. Independent third party inspection is required to verify installation according to code and contract documents. As a minimum, it is recommended that inspection items include installation of the water-resistive barrier, flashings, and accessories, Cement Board MD Finish System materials, and sealants.

3.05 CLEANING

- A. All excess Cement Board MD Finish System materials shall be removed from the job site by the contractor in accordance with contract provisions.
- B. All surrounding areas, where the Cement Board MD Finish System has been applied, shall be left free of debris and foreign substances resulting from the contractor's work.

3.06 PROTECTION

- A. The system shall be protected from weather and other damage until permanent protection in the form of flashings, sealants, etc. are installed.

CAUTIONS AND LIMITATIONS

- Use is limited to applications on projects not exceeding 5 stories.
- Minor cracking is possible in the finished exterior surface.
- Non-insulated claddings may exhibit shadowing (ghosting) of fasteners and or framing members due to varying exterior surface temperatures. Critical light will tend to exaggerate construction irregularities when coatings are applied directly to sheathing in framed construction.
- Base coat material shall not be used to level wall surface imperfections.
- Consult exterior cement board manufacturer requirements for stud spacing, fastening requirements and other design and installation considerations.

DISCLAIMER

Information contained in this specification conforms to standard detail and product recommendations for the installation of the Cement Board MD Finish System products as of the date of publication of this document and is presented in good faith. Dryvit Systems, Inc. assumes no liability, expressed or implied, as to the architecture, engineering or workmanship of any project. To ensure that you are using the latest, most complete information, contact Dryvit Systems, Inc. at:

One Energy Way
West Warwick, RI 02893
(401) 822-4100
www.dryvit.com

CEMENT BOARD MD FINISH SYSTEM™



DS190

**An Exterior Finish System Applied Over Exterior Cement Board
With A Water-Resistive Barrier And Moisture Drainage**

Cement Board MD Finish System Installation Details

DETAIL	PAGE	NOTE
System Layout	CBMD 0.0.01	DRYVIT MAKES NO REPRESENTATION REGARDING CONFORMITY OF ITS SUGGESTIONS TO MODEL BUILDING CODES, ENGINEERING CRITERIA, SPECIFIC APPLICATIONS OR PROJECT LOCATIONS. ALL COMPONENTS INDICATED IN ILLUSTRATIONS, AS WELL AS OTHERS THAT MAY BE REQUIRED FOR THE INTEGRITY OF THE SYSTEM SHALL BE DESIGNED, DETAILED AND ENGINEERED BY REPRESENTATIVES OF THE ARCHITECT, OWNER OR CONTRACTOR TO BE IN CONFORMANCE WITH MODEL CODES, ARCHITECTURAL AND ENGINEERING REQUIREMENTS PERTAINING TO SPECIFIC BUILDING PROJECTS.
Termination at Foundation	CBMD 0.0.02	
Expansion Joint at Floor Line	CBMD 0.0.03	
Opening Preparation for Storefront Window	CBMD 0.0.04	
Storefront Window Sill/Jamb	CBMD 0.0.05	
Storefront Window Head	CBMD 0.0.06	
Flanged Window Sill/Jamb	CBMD 0.0.07	
Flanged Window Head	CBMD 0.0.08	
Railing Attachment	CBMD 0.0.09	
Vent Penetration	CBMD 0.0.10	
Termination at Sloped Roof	CBMD 0.0.11	
Parapet/Wall Intersection	CBMD 0.0.12	
Parapet Termination	CBMD 0.0.13	
Termination at Deck	CBMD 0.0.14	
Soffit/Fascia Termination	CBMD 0.0.15	
Vertical Control/Expansion Joint	CBMD 0.0.16	
Outside Corner	CBMD 0.0.17	
EPS Shape Attachment	CBMD 0.0.18	
		DRYVIT MAKES NO WARRANTY, EXPRESSED OR IMPLIED, AS TO THE ARCHITECTURAL DESIGN, ENGINEERING, OR WORKMANSHIP OF PROJECTS UTILIZING DRYVIT SYSTEMS OR PRODUCTS.
		THE LIABILITIES OF DRYVIT SHALL BE AS STATED IN THE DRYVIT STANDARD WARRANTY. CONTACT DRYVIT FOR A FULL AND COMPLETE COPY OF THIS WARRANTY.

The architecture, engineering, and design of the project using the Dryvit products is the responsibility of the project's design professional. All systems must comply with local building codes and standards. This detail is for general information and guidance only and Dryvit specifically disclaims any liability for the use of this detail and for the architecture, design, engineering or workmanship of any project. The project design professional determines, in its sole discretion, whether this detail or a functionally equivalent detail is best suited for the project. Use of a functionally equivalent detail does not violate Dryvit's warranty. This detail is subject to change without notice. Contact Dryvit to ensure you have the most recent version.



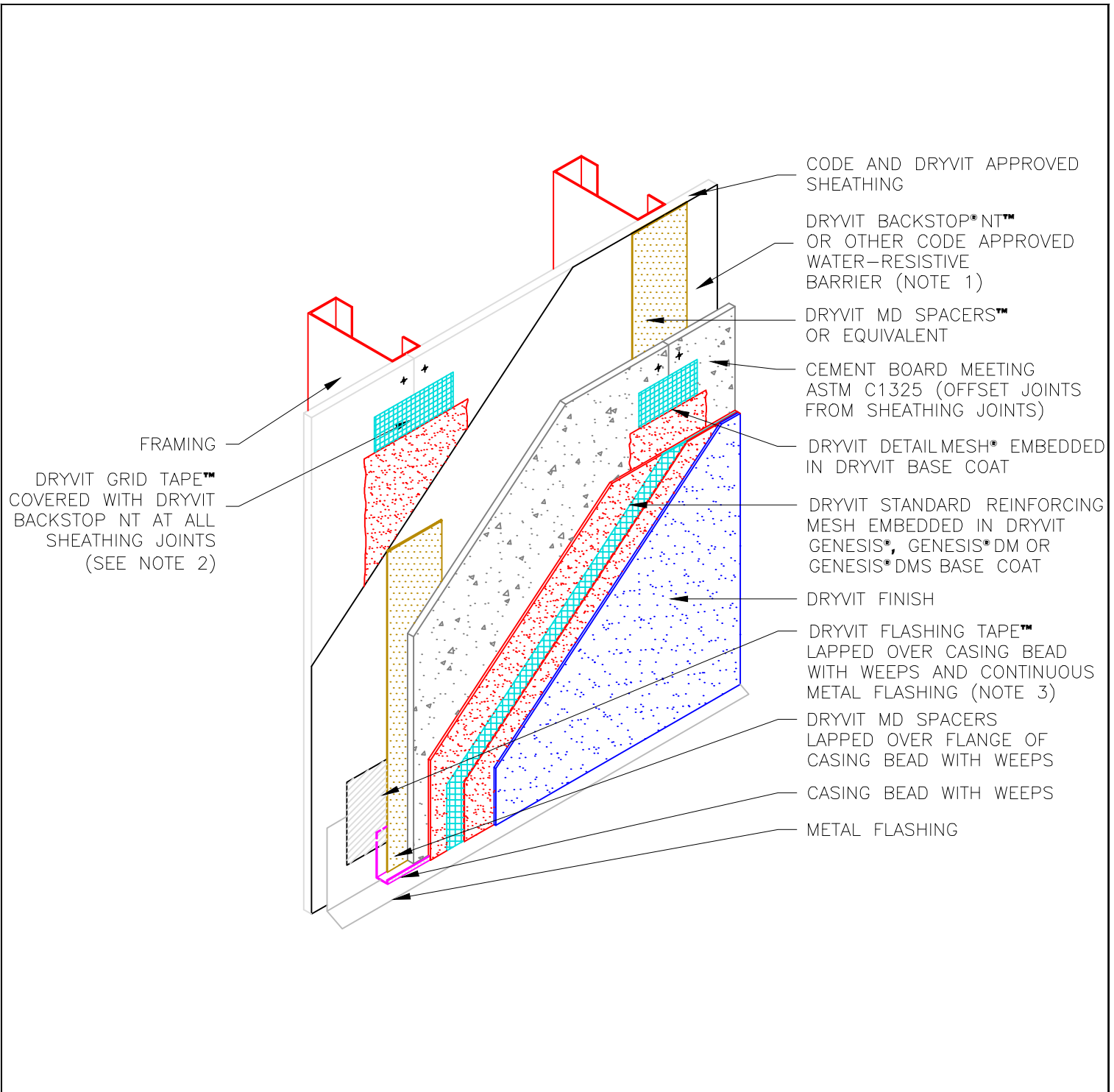

Cement Board MD Finish System™

System Layout

NOTE:

- 1: SHEET TYPE WATER-RESISTIVE MEMBRANES SHALL BE INSTALLED IN A WEATHER BOARD FASHION
- 2: DRYVIT GRID TAPE NOT REQUIRED WHEN SHEET TYPE WATER-RESISTIVE BARRIERS ARE SPECIFIED
- 3: DRYVIT AQUAFLASH® SYSTEM MAY BE USED IN LIEU OF DRYVIT FLASHING TAPE WHEN DRYVIT BACKSTOP NT IS USED AS THE WATER-RESISTIVE BARRIER

The architecture, engineering, and design of the project using the Dryvit products is the responsibility of the project's design professional. All systems must comply with local building codes and standards. This detail is for general information and guidance only and Dryvit specifically disclaims any liability for the use of this detail and for the architecture, design, engineering or workmanship of any project. The project design professional determines, in its sole discretion, whether this detail or a functionally equivalent detail is best suited for the project. Use of a functionally equivalent detail does not violate Dryvit's warranty. This detail is subject to change without notice. Contact Dryvit to ensure you have the most recent version.



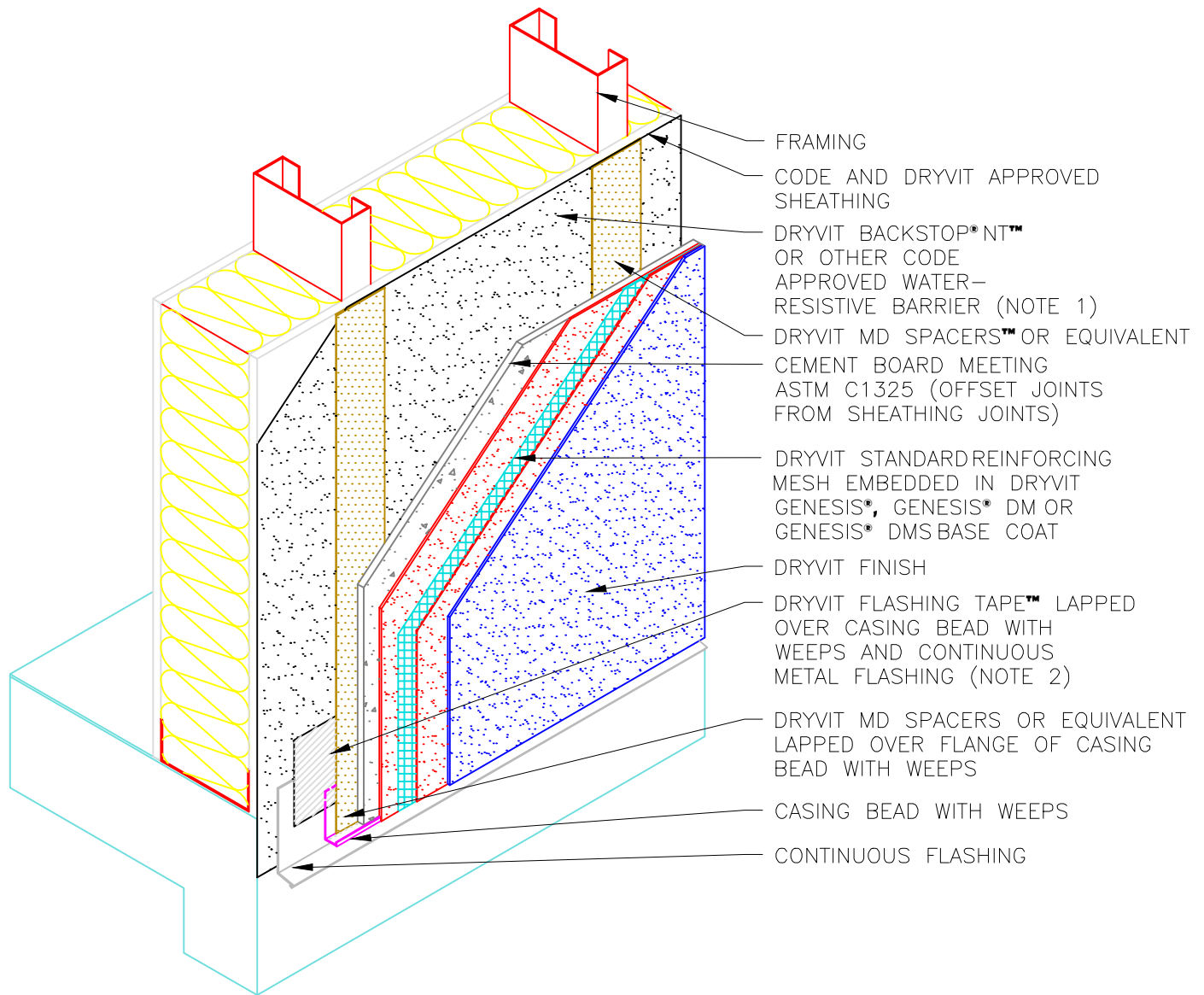

Cement Board MD Finish System™

Termination at Foundation

NOTE:

- 1: SHEET TYPE WATER-RESISTIVE MEMBRANES SHALL BE INSTALLED IN A WEATHER BOARD FASHION
- 2: DRYVIT AQUAFLASH® SYSTEM MAY BE USED IN LIEU OF DRYVIT FLASHING TAPE WHEN DRYVIT BACKSTOP NT IS USED AS THE WATER-RESISTIVE BARRIER

The architecture, engineering, and design of the project using the Dryvit products is the responsibility of the project's design professional. All systems must comply with local building codes and standards. This detail is for general information and guidance only and Dryvit specifically disclaims any liability for the use of this detail and for the architecture, design, engineering or workmanship of any project. The project design professional determines, in its sole discretion, whether this detail or a functionally equivalent detail is best suited for the project. Use of a functionally equivalent detail does not violate Dryvit's warranty. This detail is subject to change without notice. Contact Dryvit to ensure you have the most recent version.

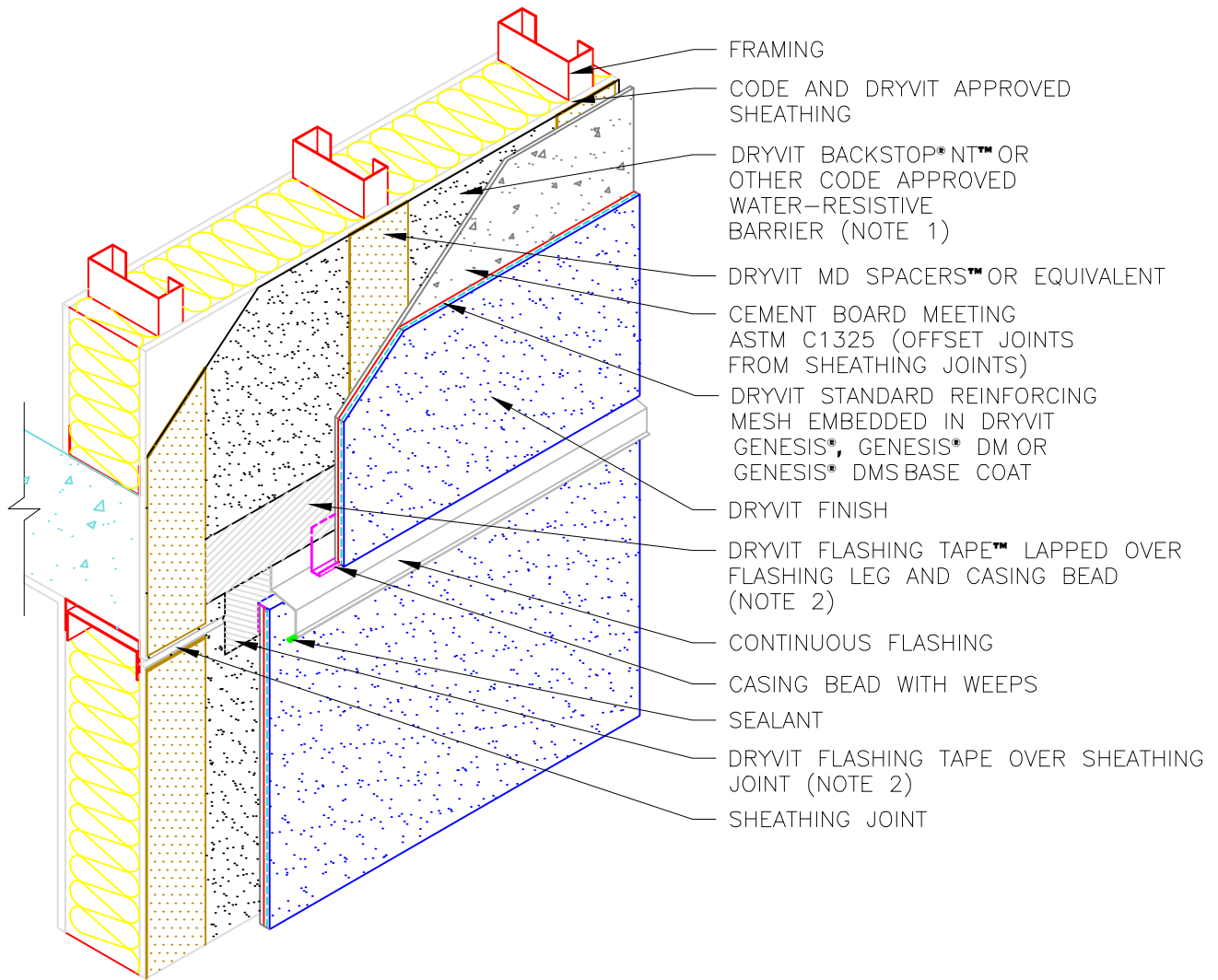

Cement Board MD Finish System™ Expansion Joint at Floor Line

NOTE:

- 1: SHEET TYPE WATER-RESISTIVE MEMBRANES SHALL BE INSTALLED IN A WEATHER BOARD FASHION
- 2: DRYVIT AQUAFLASH® SYSTEM MAY BE USED IN LIEU OF DRYVIT FLASHING TAPE WHEN DRYVIT BACKSTOP NT IS USED AS THE WATER-RESISTIVE BARRIER

The architecture, engineering, and design of the project using the Dryvit products is the responsibility of the project's design professional. All systems must comply with local building codes and standards. This detail is for general information and guidance only and Dryvit specifically disclaims any liability for the use of this detail and for the architecture, design, engineering or workmanship of any project. The project design professional determines, in its sole discretion, whether this detail or a functionally equivalent detail is best suited for the project. Use of a functionally equivalent detail does not violate Dryvit's warranty. This detail is subject to change without notice. Contact Dryvit to ensure you have the most recent version.



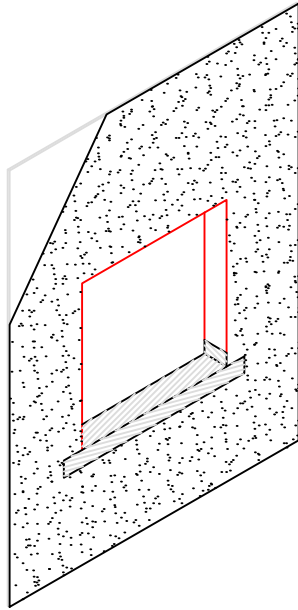

STEP 1: APPLY DRYVIT BACKSTOP*NT™ TO THE FACE OF THE WALL AND INSTALL DRYVIT FLASHING TAPE AT SILL AND LAP ONTO JAMB

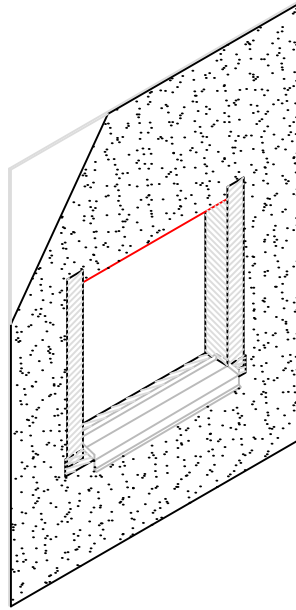

STEP 2: INSTALL SILL PAN FLASHING AND APPLY DRYVIT FLASHING TAPE™ AT JAMBS AND LAP ONTO UPTURNED EDGE OF PAN FLASHING

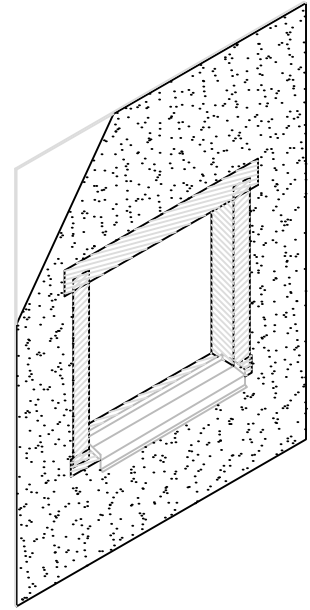

STEP 3: INSTALL HEAD FLASHING TAPE LAPPING OVER JAMB FLASHING

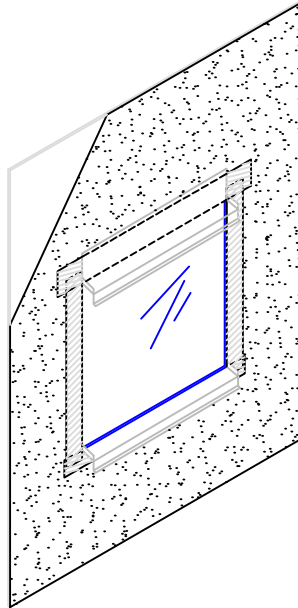

STEP 4: INSTALL WINDOW UNIT AND HEAD FLASHING

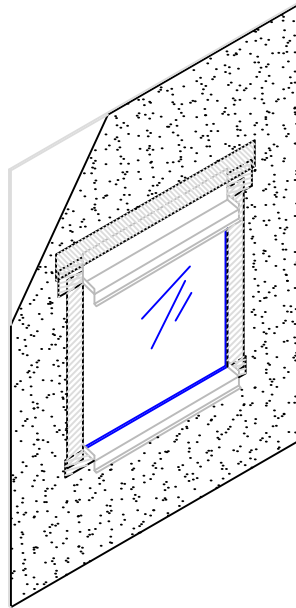

STEP 5: APPLY FLASHING TAPE OVER METAL FLASHING AT WINDOW HEAD

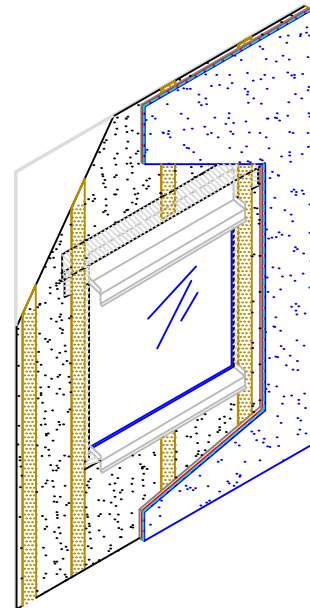

STEP 6: INSTALL MD SPACERS OR EQUIVALENT, CEMENT BOARD AND COATINGS

Cement Board MD Finish System™

Opening Preparation for Storefront Window

NOTE:

- 1: FLASHING TAPE SHALL EXTEND TO INSIDE FACE OF FRAMING
- 2: SHEET TYPE WATER RESISTIVE MEMBRANES SHALL BE INSTALLED IN A WEATHER BOARD FASHION
- 3: DRYVIT AQUAFLASH® SYSTEM MAY BE USED IN LIEU OF DRYVIT FLASHING TAPE WHEN DRYVIT BACKSTOP NT IS USED AS THE WATER-RESISTIVE BARRIER

The architecture, engineering, and design of the project using the Dryvit products is the responsibility of the project's design professional. All systems must comply with local building codes and standards. This detail is for general information and guidance only and Dryvit specifically disclaims any liability for the use of this detail and for the architecture, design, engineering or workmanship of any project. The project design professional determines, in its sole discretion, whether this detail or a functionally equivalent detail is best suited for the project. Use of a functionally equivalent detail does not violate Dryvit's warranty. This detail is subject to change without notice. Contact Dryvit to ensure you have the most recent version.



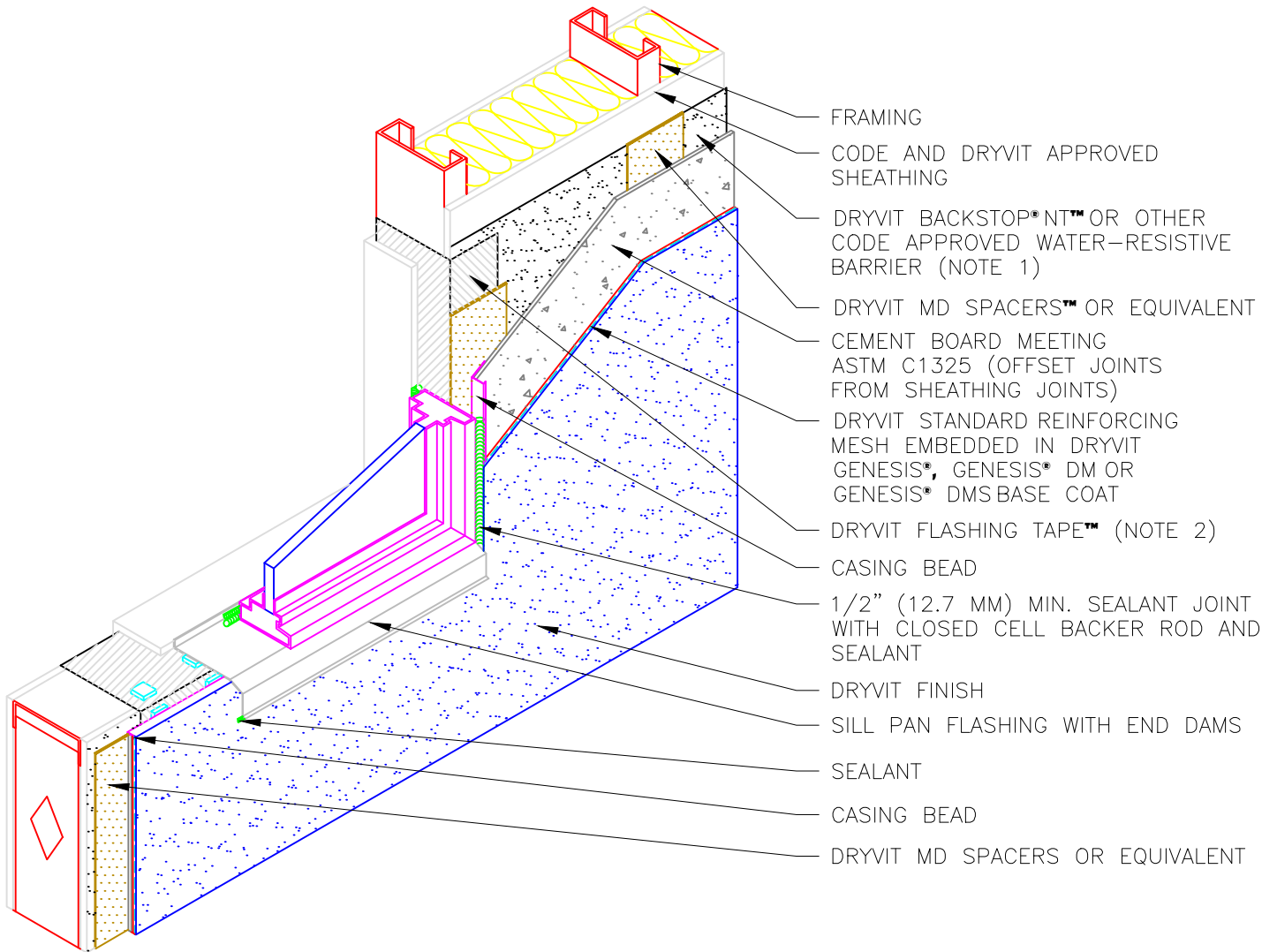

Cement Board MD Finish System™ Storefront Window Sill/Jamb

NOTE:

- 1: SHEET TYPE WATER-RESISTIVE MEMBRANES SHALL BE INSTALLED IN A WEATHER BOARD FASHION
- 2: DRYVIT AQUAFLASH® SYSTEM MAY BE USED IN LIEU OF DRYVIT FLASHING TAPE WHEN DRYVIT BACKSTOP NT IS USED AS THE WATER-RESISTIVE BARRIER

The architecture, engineering, and design of the project using the Dryvit products is the responsibility of the project's design professional. All systems must comply with local building codes and standards. This detail is for general information and guidance only and Dryvit specifically disclaims any liability for the use of this detail and for the architecture, design, engineering or workmanship of any project. The project design professional determines, in its sole discretion, whether this detail or a functionally equivalent detail is best suited for the project. Use of a functionally equivalent detail does not violate Dryvit's warranty. This detail is subject to change without notice. Contact Dryvit to ensure you have the most recent version.



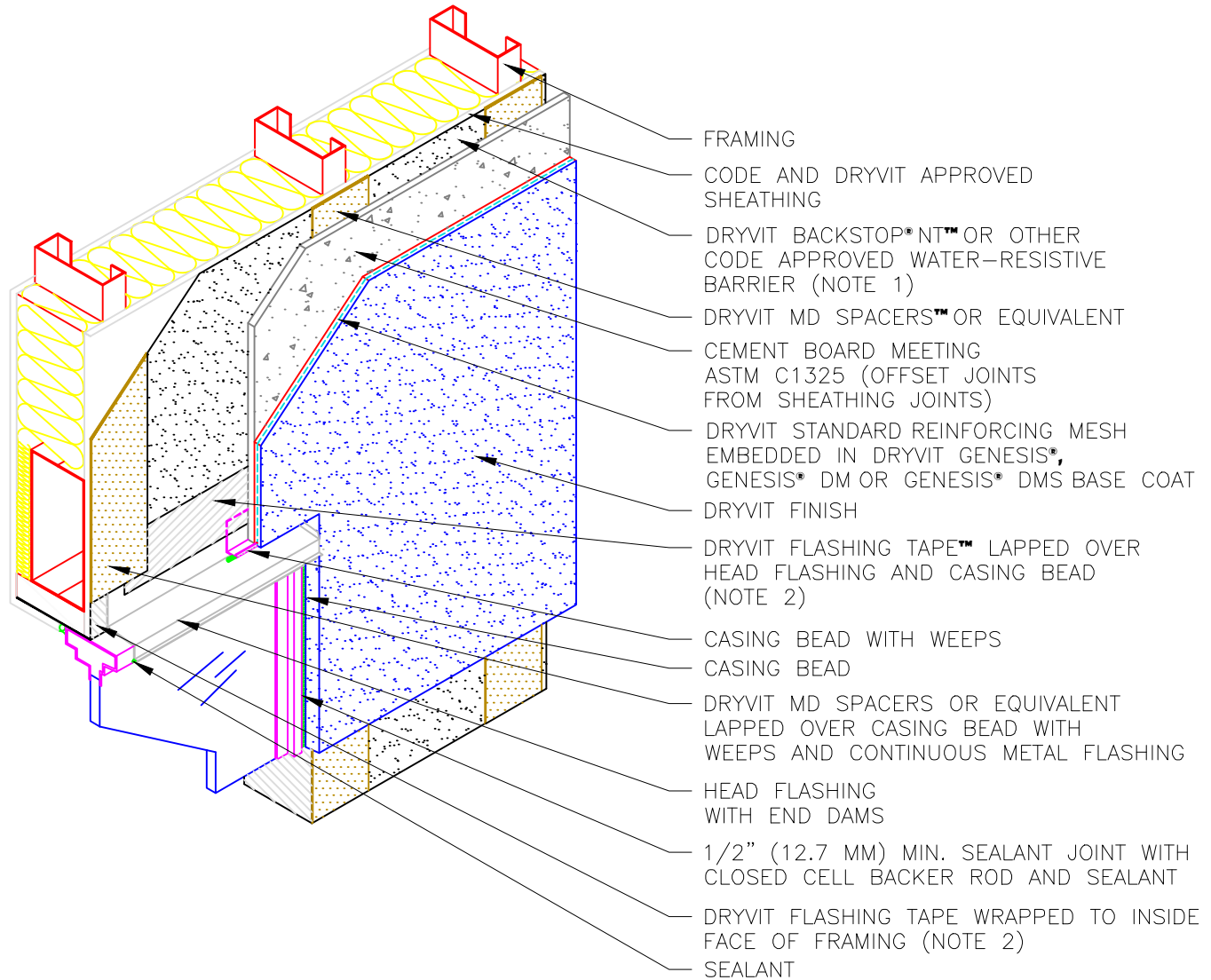

Cement Board MD Finish System™

Storefront Window Head

NOTE:

- 1: SHEET TYPE WATER-RESISTIVE MEMBRANES SHALL BE INSTALLED IN A WEATHER BOARD FASHION
- 2: DRYVIT AQUAFLASH® SYSTEM MAY BE USED IN LIEU OF DRYVIT FLASHING TAPE WHEN DRYVIT BACKSTOP NT IS USED AS THE WATER-RESISTIVE BARRIER

The architecture, engineering, and design of the project using the Dryvit products is the responsibility of the project's design professional. All systems must comply with local building codes and standards. This detail is for general information and guidance only and Dryvit specifically disclaims any liability for the use of this detail and for the architecture, design, engineering or workmanship of any project. The project design professional determines, in its sole discretion, whether this detail or a functionally equivalent detail is best suited for the project. Use of a functionally equivalent detail does not violate Dryvit's warranty. This detail is subject to change without notice. Contact Dryvit to ensure you have the most recent version.



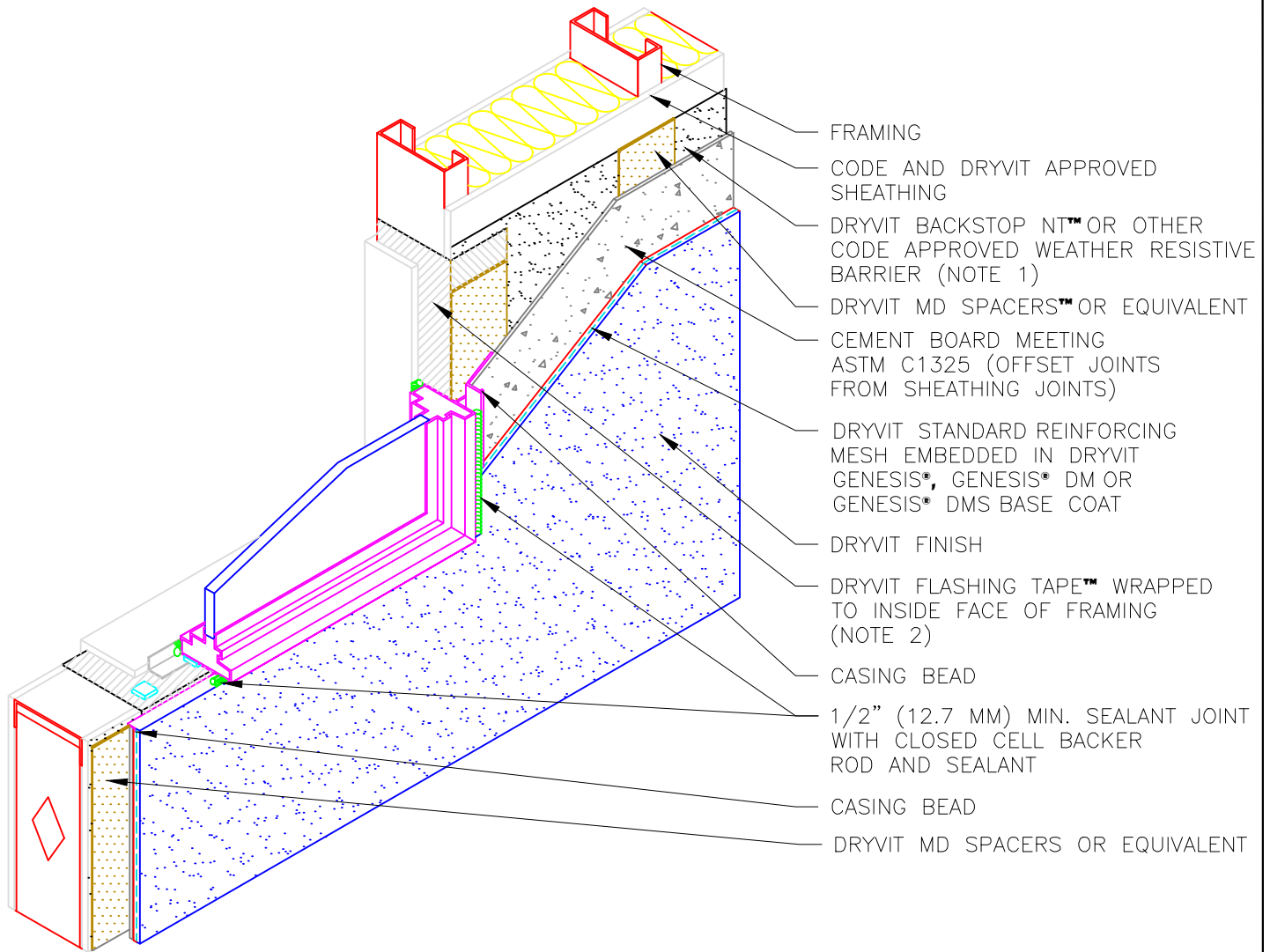

Cement Board MD Finish System™

Flanged Window Sill/Jamb

NOTE:

- 1: SHEET TYPE WATER-RESISTIVE MEMBRANES SHALL BE INSTALLED IN A WEATHER BOARD FASHION
- 2: DRYVIT AQUAFLASH® SYSTEM MAY BE USED IN LIEU OF DRYVIT FLASHING TAPE WHEN DRYVIT BACKSTOP NT IS USED AS THE WATER-RESISTIVE BARRIER

The architecture, engineering, and design of the project using the Dryvit products is the responsibility of the project's design professional. All systems must comply with local building codes and standards. This detail is for general information and guidance only and Dryvit specifically disclaims any liability for the use of this detail and for the architecture, design, engineering or workmanship of any project. The project design professional determines, in its sole discretion, whether this detail or a functionally equivalent detail is best suited for the project. Use of a functionally equivalent detail does not violate Dryvit's warranty. This detail is subject to change without notice. Contact Dryvit to ensure you have the most recent version.

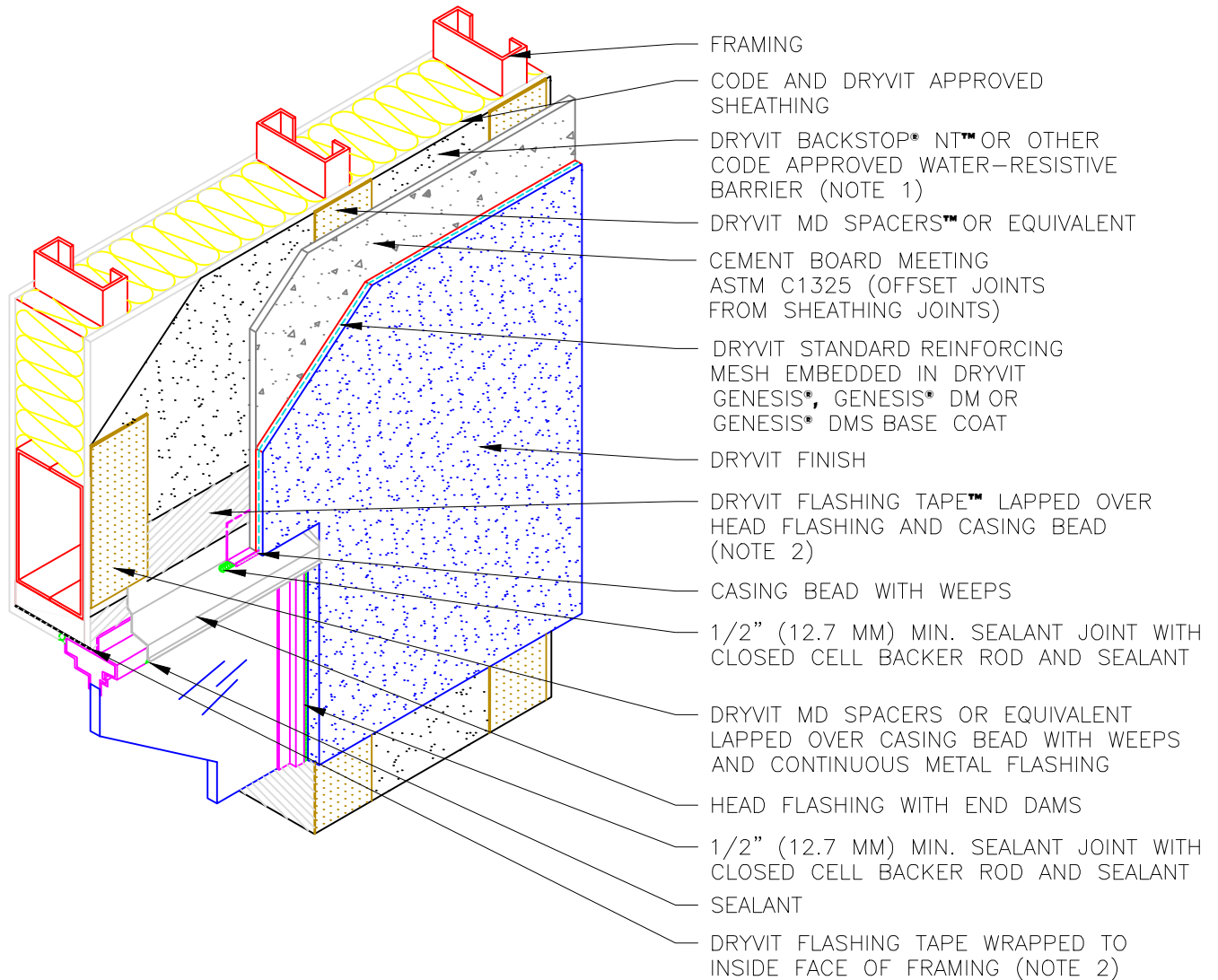

Cement Board MD Finish System™

Flanged Window Head

NOTE:

- 1: SHEET TYPE WATER-RESISTIVE MEMBRANES SHALL BE INSTALLED IN A WEATHER BOARD FASHION
- 2: DRYVIT AQUAFLASH® SYSTEM MAY BE USED IN LIEU OF DRYVIT FLASHING TAPE WHEN DRYVIT BACKSTOP NT IS USED AS THE WATER-RESISTIVE BARRIER

The architecture, engineering, and design of the project using the Dryvit products is the responsibility of the project's design professional. All systems must comply with local building codes and standards. This detail is for general information and guidance only and Dryvit specifically disclaims any liability for the use of this detail and for the architecture, design, engineering or workmanship of any project. The project design professional determines, in its sole discretion, whether this detail or a functionally equivalent detail is best suited for the project. Use of a functionally equivalent detail does not violate Dryvit's warranty. This detail is subject to change without notice. Contact Dryvit to ensure you have the most recent version.



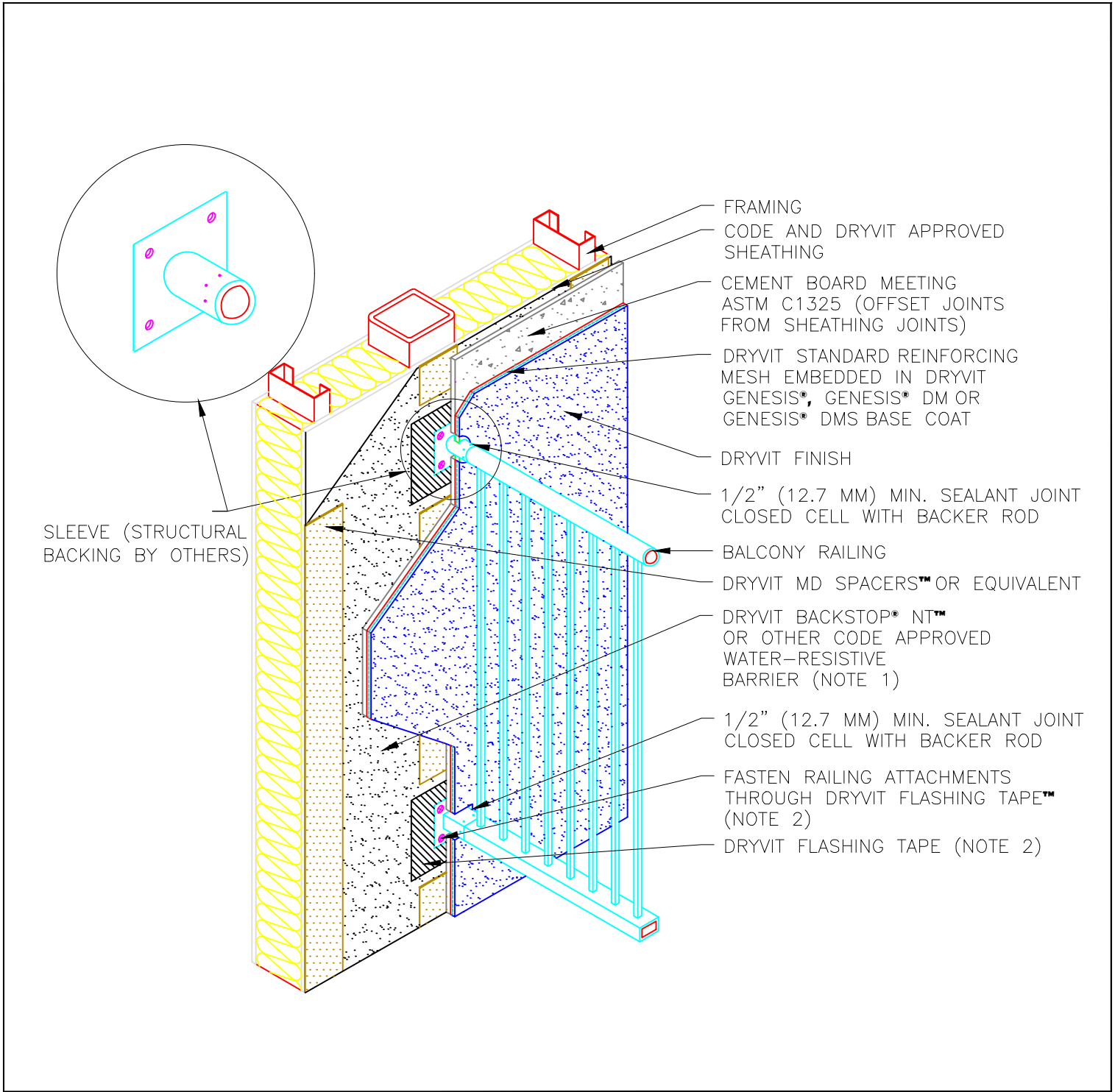

Cement Board MD Finish System™

Railing Attachment

NOTE:

- 1: SHEET TYPE WATER-RESISTIVE MEMBRANES SHALL BE INSTALLED IN A WEATHER BOARD FASHION
- 2: DRYVIT AQUAFLASH® SYSTEM MAY BE USED IN LIEU OF DRYVIT FLASHING TAPE WHEN DRYVIT BACKSTOP NT IS USED AS THE WATER-RESISTIVE BARRIER

The architecture, engineering, and design of the project using the Dryvit products is the responsibility of the project's design professional. All systems must comply with local building codes and standards. This detail is for general information and guidance only and Dryvit specifically disclaims any liability for the use of this detail and for the architecture, design, engineering or workmanship of any project. The project design professional determines, in its sole discretion, whether this detail or a functionally equivalent detail is best suited for the project. Use of a functionally equivalent detail does not violate Dryvit's warranty. This detail is subject to change without notice. Contact Dryvit to ensure you have the most recent version.



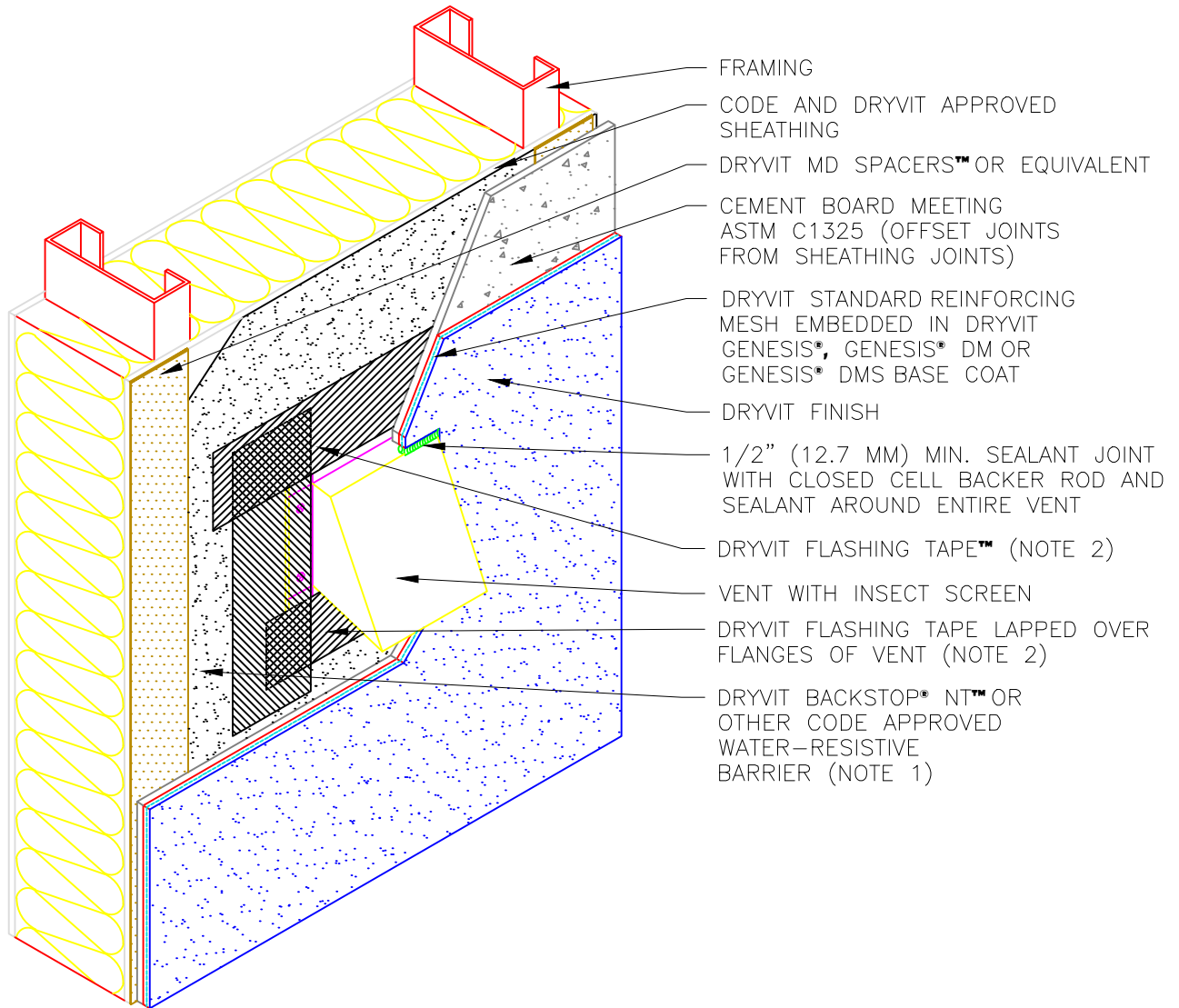

Cement Board MD Finish System™

Vent Penetration

NOTE:

- 1: SHEET TYPE WATER-RESISTIVE MEMBRANES SHALL BE INSTALLED IN A WEATHER BOARD FASHION
- 2: DRYVIT AQUAFLASH® SYSTEM MAY BE USED IN LIEU OF DRYVIT FLASHING TAPE WHEN DRYVIT BACKSTOP NT IS USED AS THE WATER-RESISTIVE BARRIER

The architecture, engineering, and design of the project using the Dryvit products is the responsibility of the project's design professional. All systems must comply with local building codes and standards. This detail is for general information and guidance only and Dryvit specifically disclaims any liability for the use of this detail and for the architecture, design, engineering or workmanship of any project. The project design professional determines, in its sole discretion, whether this detail or a functionally equivalent detail is best suited for the project. Use of a functionally equivalent detail does not violate Dryvit's warranty. This detail is subject to change without notice. Contact Dryvit to ensure you have the most recent version.

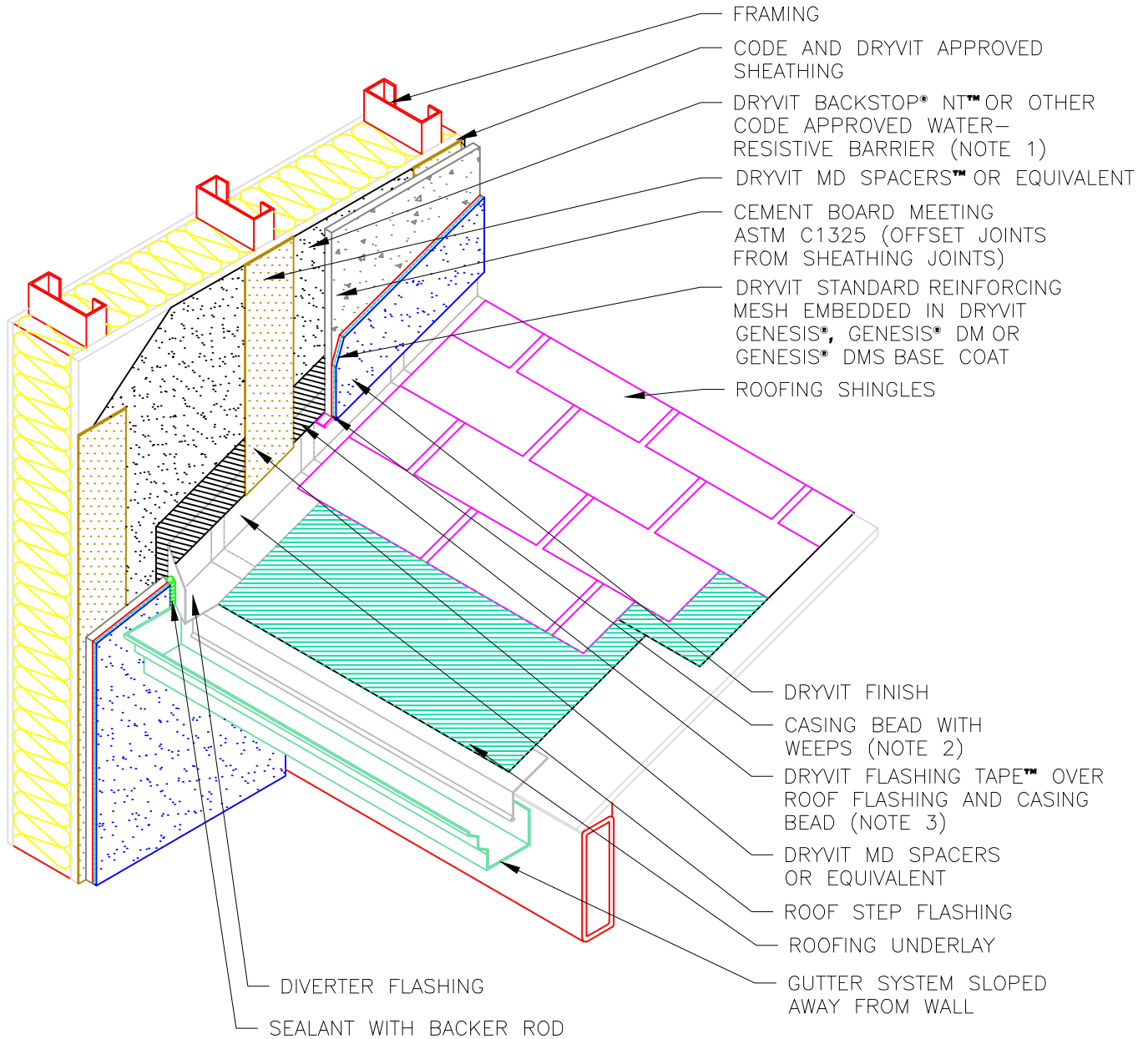

Cement Board MD Finish System™ Termination at Sloped Roof

NOTE:

- 1: SHEET TYPE WATER-RESISTIVE MEMBRANES SHALL BE INSTALLED IN A WEATHER BOARD FASHION
- 2: TERMINATE SYSTEM MIN. 2" (50 MM) OFF ROOF
- 3: DRYVIT AQUAFLASH® SYSTEM MAY BE USED IN LIEU OF DRYVIT FLASHING TAPE WHEN DRYVIT BACKSTOP NT IS USED AS THE WATER-RESISTIVE BARRIER

The architecture, engineering, and design of the project using the Dryvit products is the responsibility of the project's design professional. All systems must comply with local building codes and standards. This detail is for general information and guidance only and Dryvit specifically disclaims any liability for the use of this detail and for the architecture, design, engineering or workmanship of any project. The project design professional determines, in its sole discretion, whether this detail or a functionally equivalent detail is best suited for the project. Use of a functionally equivalent detail does not violate Dryvit's warranty. This detail is subject to change without notice. Contact Dryvit to ensure you have the most recent version.



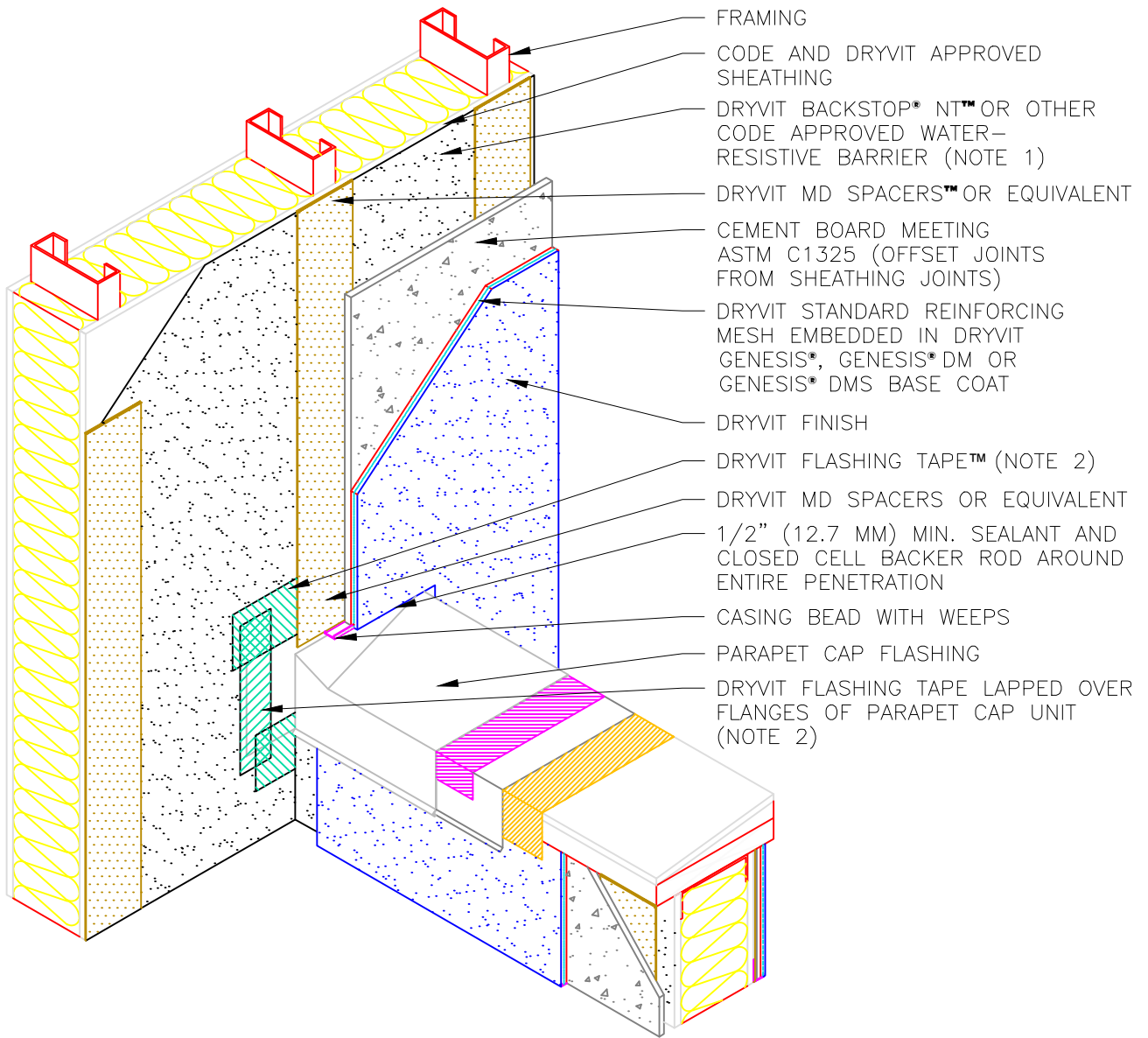

Cement Board MD Finish System™

Parapet Wall Intersection

NOTE:

- 1: SHEET TYPE WATER-RESISTIVE MEMBRANES SHALL BE INSTALLED IN A WEATHER BOARD FASHION
- 2: DRYVIT AQUAFASH® SYSTEM MAY BE USED IN LIEU OF DRYVIT FLASHING TAPE WHEN DRYVIT BACKSTOP NT IS USED AS THE WATER-RESISTIVE BARRIER

The architecture, engineering, and design of the project using the Dryvit products is the responsibility of the project's design professional. All systems must comply with local building codes and standards. This detail is for general information and guidance only and Dryvit specifically disclaims any liability for the use of this detail and for the architecture, design, engineering or workmanship of any project. The project design professional determines, in its sole discretion, whether this detail or a functionally equivalent detail is best suited for the project. Use of a functionally equivalent detail does not violate Dryvit's warranty. This detail is subject to change without notice. Contact Dryvit to ensure you have the most recent version.



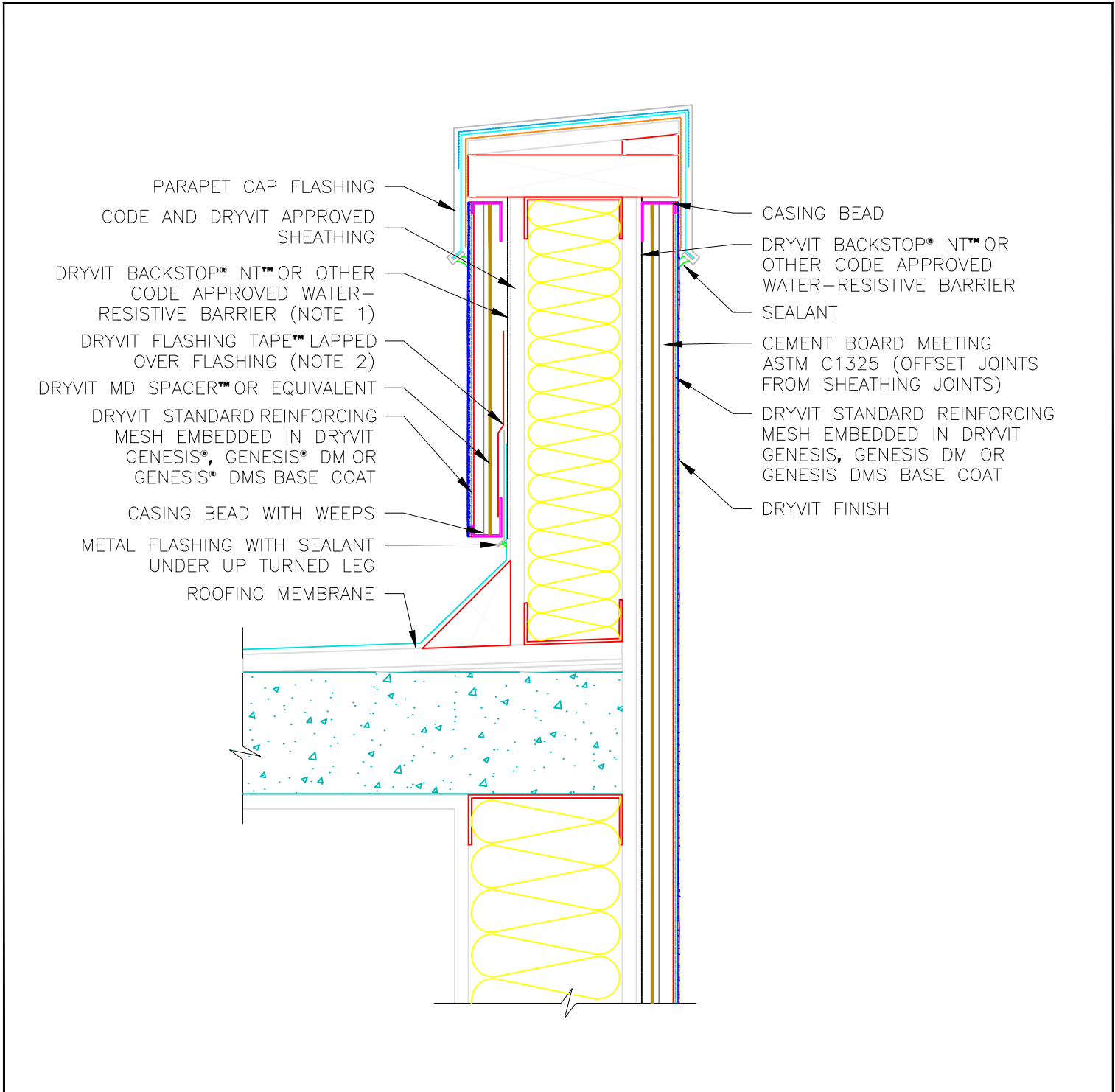

Cement Board MD Finish System™

Parapet Termination

NOTE:

- 1: SHEET TYPE WATER-RESISTIVE MEMBRANES SHALL BE INSTALLED IN A WEATHER BOARD FASHION
- 2: DRYVIT AQUAFLASH® SYSTEM MAY BE USED IN LIEU OF DRYVIT FLASHING TAPE WHEN DRYVIT BACKSTOP NT IS USED AS THE WATER-RESISTIVE BARRIER

The architecture, engineering, and design of the project using the Dryvit products is the responsibility of the project's design professional. All systems must comply with local building codes and standards. This detail is for general information and guidance only and Dryvit specifically disclaims any liability for the use of this detail and for the architecture, design, engineering or workmanship of any project. The project design professional determines, in its sole discretion, whether this detail or a functionally equivalent detail is best suited for the project. Use of a functionally equivalent detail does not violate Dryvit's warranty. This detail is subject to change without notice. Contact Dryvit to ensure you have the most recent version.

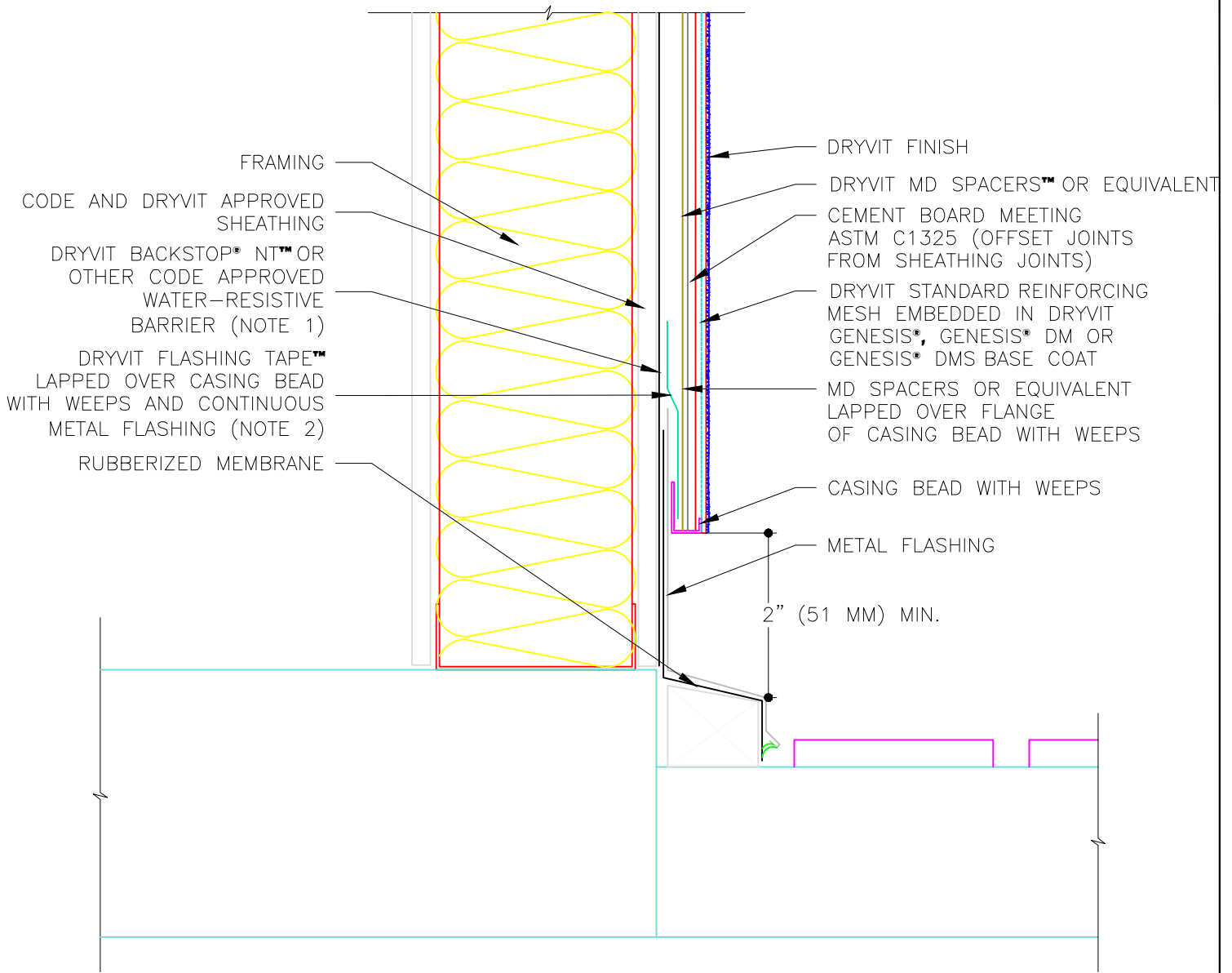

Cement Board MD Finish System™

Termination at Deck

NOTE:

- 1: SHEET TYPE WATER-RESISTIVE MEMBRANES SHALL BE INSTALLED IN A WEATHER BOARD FASHION
- 2: DRYVIT AQUAFLASH® SYSTEM MAY BE USED IN LIEU OF DRYVIT FLASHING TAPE WHEN DRYVIT BACKSTOP NT IS USED AS THE WATER-RESISTIVE BARRIER

The architecture, engineering, and design of the project using the Dryvit products is the responsibility of the project's design professional. All systems must comply with local building codes and standards. This detail is for general information and guidance only and Dryvit specifically disclaims any liability for the use of this detail and for the architecture, design, engineering or workmanship of any project. The project design professional determines, in its sole discretion, whether this detail or a functionally equivalent detail is best suited for the project. Use of a functionally equivalent detail does not violate Dryvit's warranty. This detail is subject to change without notice. Contact Dryvit to ensure you have the most recent version.



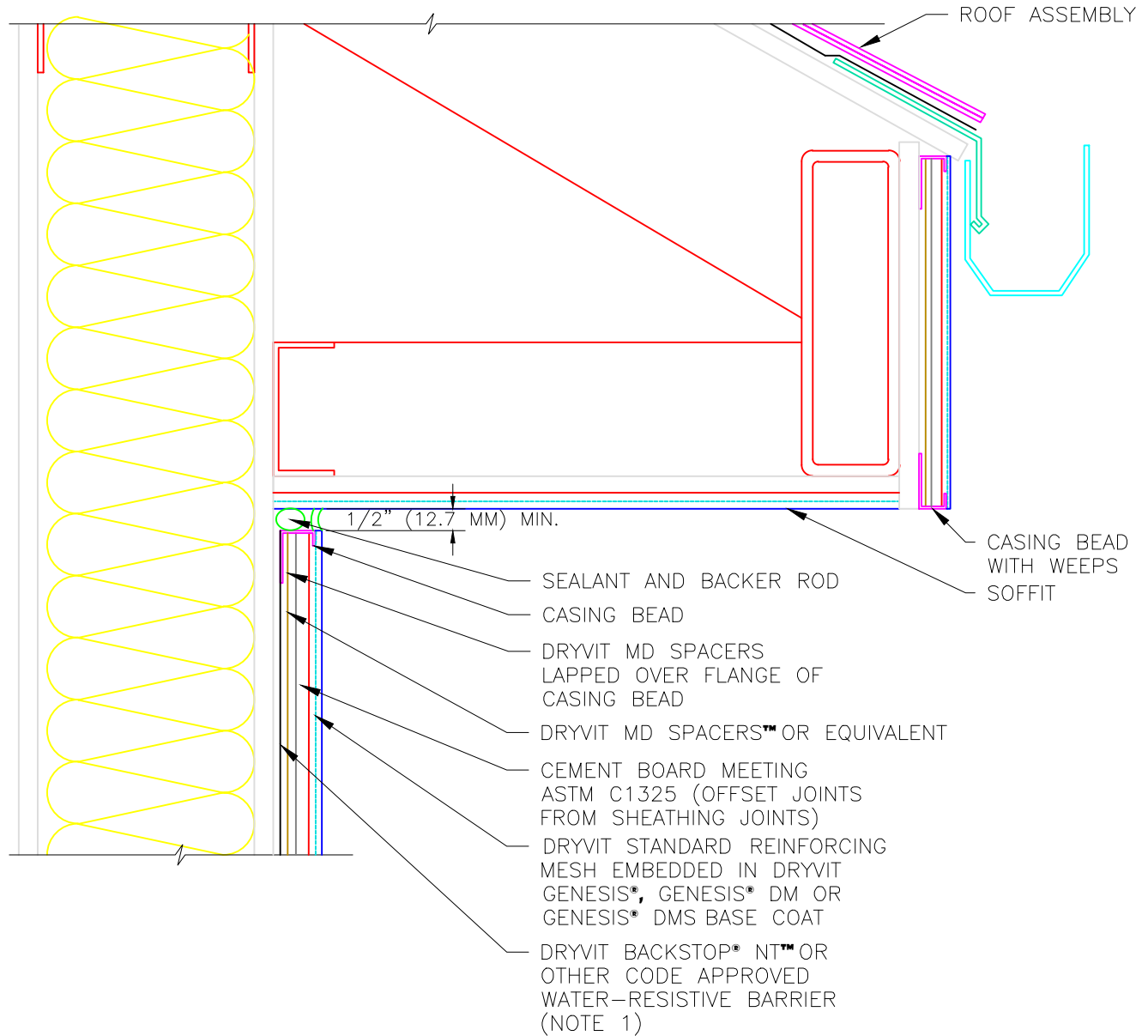

Cement Board MD Finish System™

Soffit/Fascia Termination

NOTE:

- 1: SHEET TYPE WATER-RESISTIVE MEMBRANES SHALL BE INSTALLED IN A WEATHER BOARD FASHION

The architecture, engineering, and design of the project using the Dryvit products is the responsibility of the project's design professional. All systems must comply with local building codes and standards. This detail is for general information and guidance only and Dryvit specifically disclaims any liability for the use of this detail and for the architecture, design, engineering or workmanship of any project. The project design professional determines, in its sole discretion, whether this detail or a functionally equivalent detail is best suited for the project. Use of a functionally equivalent detail does not violate Dryvit's warranty. This detail is subject to change without notice. Contact Dryvit to ensure you have the most recent version.

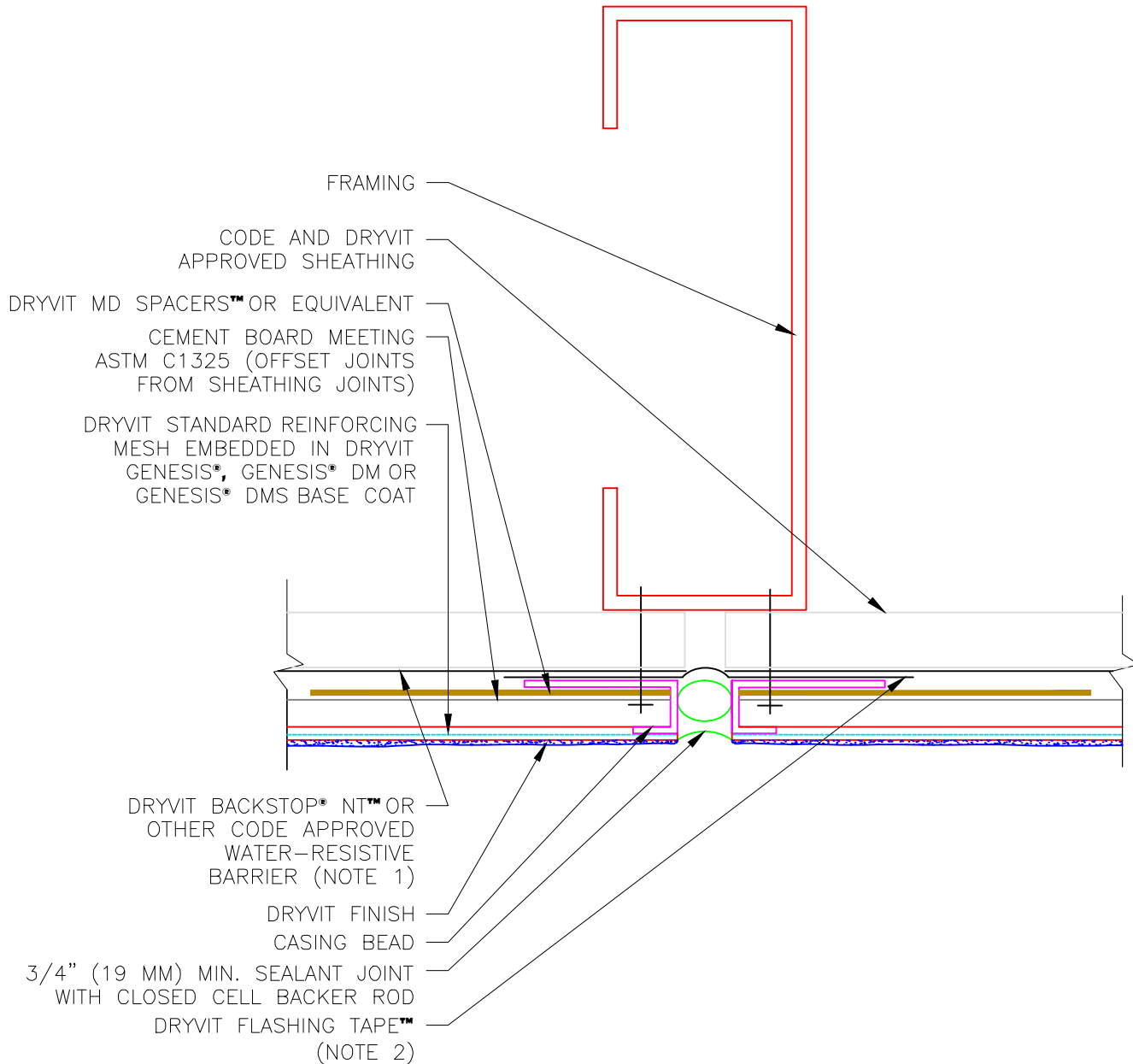

Cement Board MD Finish System™ Vertical Control/Expansion Joint

NOTE:

- 1: SHEET TYPE WATER-RESISTIVE MEMBRANES SHALL BE INSTALLED IN A WEATHER BOARD FASHION
- 2: DRYVIT AQUAFLASH® SYSTEM MAY BE USED IN LIEU OF DRYVIT FLASHING TAPE WHEN DRYVIT BACKSTOP NT IS USED AS THE WATER-RESISTIVE BARRIER

The architecture, engineering, and design of the project using the Dryvit products is the responsibility of the project's design professional. All systems must comply with local building codes and standards. This detail is for general information and guidance only and Dryvit specifically disclaims any liability for the use of this detail and for the architecture, design, engineering or workmanship of any project. The project design professional determines, in its sole discretion, whether this detail or a functionally equivalent detail is best suited for the project. Use of a functionally equivalent detail does not violate Dryvit's warranty. This detail is subject to change without notice. Contact Dryvit to ensure you have the most recent version.



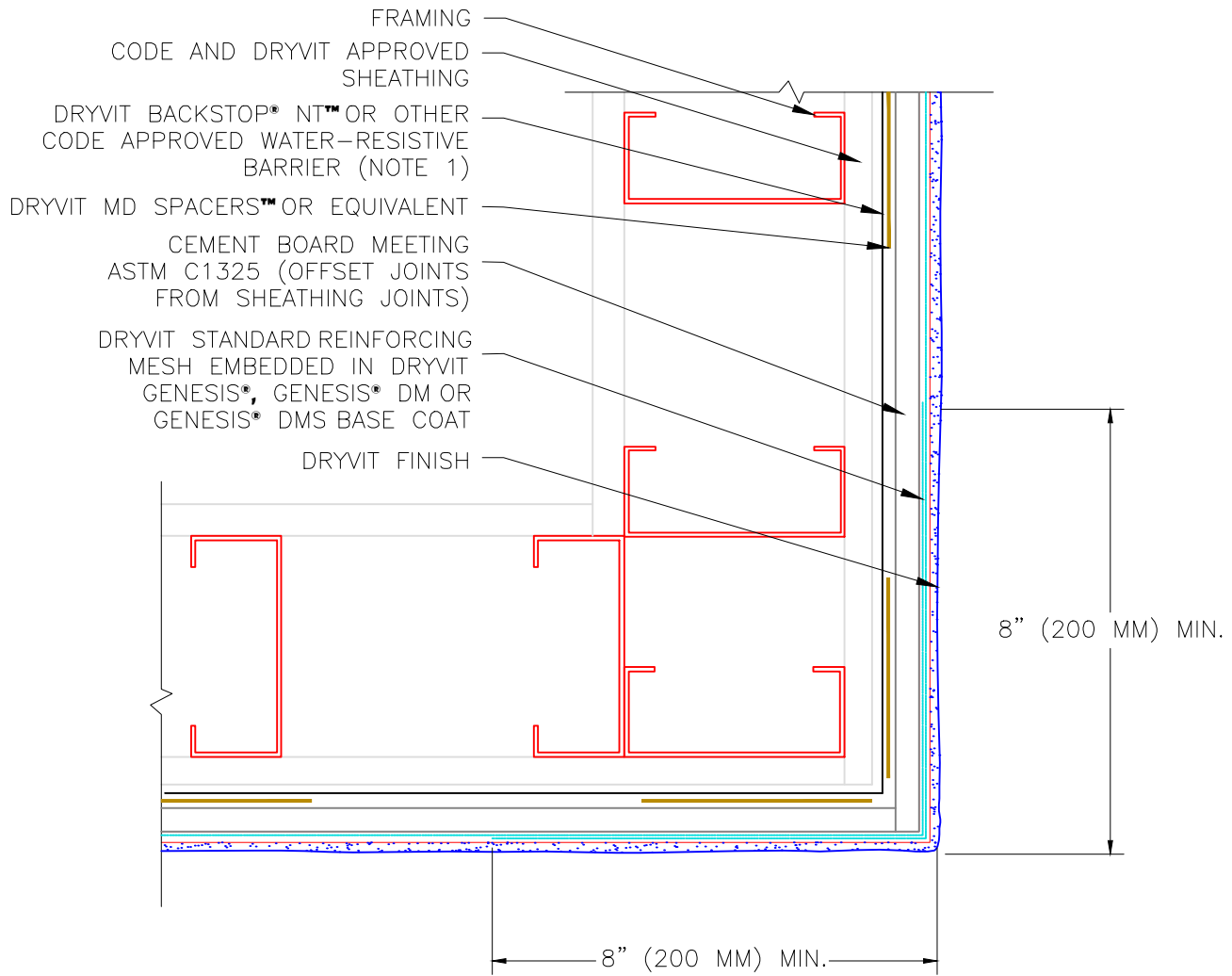

Cement Board MD Finish System™

Outside Corner

NOTE:

- 1: SHEET TYPE WATER-RESISTIVE MEMBRANES SHALL BE INSTALLED IN A WEATHER BOARD FASHION
- 2: DO NOT LAP REINFORCING MESH WITHIN 8" (200 MM) OF OUTSIDE CORNERS

The architecture, engineering, and design of the project using the Dryvit products is the responsibility of the project's design professional. All systems must comply with local building codes and standards. This detail is for general information and guidance only and Dryvit specifically disclaims any liability for the use of this detail and for the architecture, design, engineering or workmanship of any project. The project design professional determines, in its sole discretion, whether this detail or a functionally equivalent detail is best suited for the project. Use of a functionally equivalent detail does not violate Dryvit's warranty. This detail is subject to change without notice. Contact Dryvit to ensure you have the most recent version.



